



RAM

2023 RAM TRX

PERFORMANCE FEATURES GUIDE



TABLE OF CONTENTS

1	INTRODUCTION.....	4
2	GETTING TO KNOW YOUR VEHICLE	7
3	GETTING TO KNOW YOUR INSTRUMENT PANEL	9
4	STARTING AND OPERATING	19
5	MULTIMEDIA	40
6	SAFETY	66
7	IN CASE OF EMERGENCY	69
8	SERVICING AND MAINTENANCE	79
9	TECHNICAL SPECIFICATIONS	94
10	INDEX.....	98

1

2

3

4

5

6

7

8

9

10

INTRODUCTION

SYMBOLS KEY	5
SLIDE-IN CAMPERS	5
Camper Applications.....	5
VEHICLE MODIFICATIONS/ALTERATIONS	5
SYMBOL GLOSSARY	6

GETTING TO KNOW YOUR VEHICLE

EXTERIOR LIGHTS	7
Headlight Switch.....	7
INTERIOR STORAGE AND EQUIPMENT	7
Storage.....	7
Power Inverter — If Equipped.....	8

GETTING TO KNOW YOUR
INSTRUMENT PANEL

INSTRUMENT CLUSTER	9
Premium Instrument Cluster	
Descriptions — Gasoline.....	10
INSTRUMENT CLUSTER DISPLAY	10
Instrument Cluster Display Controls.....	11
Display Menu Items.....	11
Head Up Display (HUD) — If Equipped.....	16
TRX Drive Mode.....	17
WARNING LIGHTS AND MESSAGES	18
Drive Mode Indicator Lights.....	18

STARTING AND OPERATING

ENGINE BREAK-IN RECOMMENDATIONS

6.2L SUPERCHARGED ENGINE	19
---------------------------------------	----

AUTOMATIC TRANSMISSION..... 19

Ignition Park Interlock.....	20
Brake/Transmission Shift Interlock	
(BTSI) System.....	20
8-Speed Automatic Transmission.....	21

FOUR-WHEEL DRIVE OPERATION..... 24

Four-Position Electronically Shifted	
Transfer Case.....	24
Selec-Speed Control (SSC).....	27
TRX Modes.....	29

AXLE LOCKER SYSTEM..... 32**DRIVING TIPS**..... 33

On-Road Driving Tips.....	33
Off-Road Driving Tips.....	33

MULTIMEDIA

PERFORMANCE PAGES	40
Timers	40
Gauges	42
Dynamometer (Dyno)/Engine.....	43
G-Force.....	45
Vehicle Dynamics	46
DRIVE MODES	47
On-Road	48
Off-Road	52
Custom Mode	55
Race Options	59
Guidelines For Track Or Extreme	
Off-Road Use.....	64
Valet Mode.....	65

SAFETY

SAFETY FEATURES	66
Electronic Stability Control (ESC)	66
ESC Operating Modes	67
SAFETY TIPS	68
Fluid Leaks	68

IN CASE OF EMERGENCY

JACKING AND TIRE CHANGING	69
Preparations For Jacking.....	69
Jack Location.....	69
Removal Of Jack And Tools	70
Removing The Spare Tire.....	71
Jacking Instructions	73
To Stow The Flat Or Spare	76
Reinstalling The Jack And Tools.....	77
FRONT AND REAR TOW HOOKS	78

SERVICING AND MAINTENANCE

SCHEDULED SERVICING	79
Maintenance Plan.....	81
ENGINE COMPARTMENT	85
6.2L Supercharged Engine	
(Beauty Cover Removed).....	85
VEHICLE MAINTENANCE	86
Engine Oil – Gas Engine	86
Engine Oil Filter	86
Engine Air Cleaner Filter	88
Cooling System	90
Fuses.....	90
STORING THE VEHICLE	93
Battery Storage Mode.....	93
INTERIORS	93
Suede Steering Wheel Cleaning.....	93

TECHNICAL SPECIFICATIONS

FUEL REQUIREMENTS	94
6.2L Supercharged Engine.....	94
FLUID CAPACITIES	95
ENGINE FLUIDS AND LUBRICANTS	96
GENERAL INFORMATION	97

INTRODUCTION



Dear Customer,

This Supplement has been prepared with the assistance of service and engineering specialists to acquaint you with the operation and maintenance of your Ram. Within this information, you will find a description of the services that FCA US LLC offers to its customers. Please take the time to read all of this publication carefully before driving your vehicle for the first time. Following the instructions, recommendations, tips, and important warnings in this manual will help ensure safe and enjoyable operation of your vehicle. For additional information, refer to your vehicle's Owner's Manual.

Following the instructions and recommendations provided herein will help ensure safe and reliable operation of your vehicle. After you have read the booklet, it should be stored in the vehicle for convenient reference and remain with the vehicle when sold.

When it comes to service, remember that authorized dealers know your Ram best, have factory-trained technicians, genuine Mopar® parts, and care about your satisfaction.

SYMBOLS KEY

WARNING!	These statements apply to operating procedures that could result in a collision, bodily injury and/or death.
CAUTION!	These statements apply to procedures that could result in damage to your vehicle.
NOTE:	A suggestion which will improve installation, operation, and reliability. If not followed, may result in damage.
TIP:	General ideas/solutions/suggestions on easier use of the product or functionality.
PAGE REFERENCE ARROW 	Follow this reference for additional information on a particular feature.
FOOTNOTE 	Supplementary and relevant information pertaining to the topic.

If you do not read the entire Owner's Manual, you may miss important information. Observe all Cautions and Warnings.

SLIDE-IN CAMPERS

CAMPER APPLICATIONS

This vehicle is not recommended for slide-in camper applications.

VEHICLE MODIFICATIONS/ALTERATIONS

WARNING!

Any modifications or alterations to this vehicle could seriously affect its roadworthiness and safety and may lead to a collision resulting in serious injury or death.

SYMBOL GLOSSARY

Some car components have colored labels with symbols indicating precautions to be observed when using this component. It is important to follow all warnings when operating your vehicle. See below for the definition of each symbol → page 18.

NOTE:

Warning and Indicator lights are different based upon equipment options and current vehicle status. Some telltales are optional and may not appear.

Drive Mode Indicator Lights	
SPORT	Sport Mode Indicator Light → page 18
SNOW	Snow Mode Indicator Light → page 18
TOW	Tow Mode Indicator Light → page 18

Drive Mode Indicator Lights	
BAJA	Baja Mode Indicator Light → page 18
MUD/ SAND	Mud/Sand Mode Indicator Light → page 18
ROCK	Rock Mode Indicator Light → page 18
CUSTOM	Custom Mode Indicator Light → page 18
VALET	Valet Mode Indicator Light → page 18

GETTING TO KNOW YOUR VEHICLE

EXTERIOR LIGHTS

HEADLIGHT SWITCH

The headlight switch controls the clearance lamps and the front and rear identification lamps. The clearance lamps and the front and rear identification lamps will turn on when the switch is in the On, AUTO, or parking lights position. These lamps are activated to allow other drivers to spot and identify the vehicle.



Headlight Switch

- 1 – Parking Lights Position
- 2 – Headlights On Position
- 3 – AUTO Position

Refer to “Exterior Lights” in “Getting To Know Your Vehicle” in the Owner’s Manual for further information.

INTERIOR STORAGE AND EQUIPMENT

STORAGE

2

Center Console Storage Area

The center console storage area consists of a cubby bin (located in front of the gear selector) and two cupholders (located to the right of the gear selector). If equipped with a wireless charging pad, it will be located within the cubby bin.

To access the cupholders, push on the cover to open it.



Center Console Storage Area

- 1 – Cubby Bin (With Wireless Charging Pad)
- 2 – Cupholders

NOTE:

The metal badge on the top of the center console lid will get hot to the touch if the console lid is exposed to direct sunlight, or if the vehicle is exposed to an extremely high temperature environment.

POWER INVERTER — IF EQUIPPED

A 115 Volt (400 Watt maximum) inverter may be located inside the center console storage area. This inverter can power cellular phones, electronics and other low-power devices requiring power up to 400 Watts. Certain video game consoles exceed this power limit, as will most power tools.

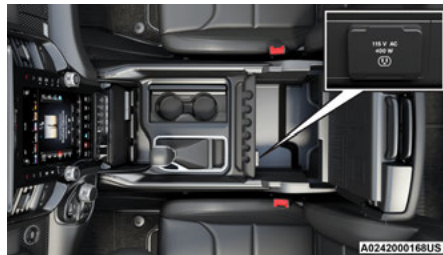

Center Console Power Inverter Outlet

The outlet remains off when no device is plugged in. To turn on the power outlet, simply plug in a device.

NOTE:

- The power inverter only turns on if the ignition is in the ACC or ON/RUN position.
- Due to a built-in overload protection, the power inverter shuts down if the power rating is exceeded.

WARNING!

To avoid serious injury or death:

- Do not insert any objects into the receptacles.
- Do not touch the outlets with wet hands.
- Close the lid when not in use.
- If this outlet is mishandled, it may cause an electric shock and failure.

GETTING TO KNOW YOUR INSTRUMENT PANEL

INSTRUMENT CLUSTER



PREMIUM INSTRUMENT CLUSTER DESCRIPTIONS — GASOLINE

1. Tachometer
 - Indicates the engine speed in revolutions per minute (RPM x 1000).
2. Speedometer
 - Indicates vehicle speed.
3. Temperature Gauge
 - The pointer shows engine coolant temperature. The pointer positioned within the normal range indicates that the engine cooling system is operating satisfactorily.
 - The pointer will likely indicate a higher temperature when driving in hot weather, up mountain grades, or when towing a trailer. It should not be allowed to exceed the upper limits of the normal operating range.

WARNING!

A hot engine cooling system is dangerous. You or others could be badly burned by steam or boiling coolant. It is recommended to call an authorized dealer for service if your vehicle overheats
 ⇨ page 90.

CAUTION!

Driving with a hot engine cooling system could damage your vehicle. If the temperature gauge reads "H," pull over and stop the vehicle. Idle the vehicle with the air conditioner turned off until the pointer drops back into the normal range. If the pointer remains on the "H," turn the engine off immediately and call an authorized dealer for service.

4. Instrument Cluster Display
 - When the appropriate conditions exist, this display shows the instrument cluster display messages.

5. Fuel Gauge

- The pointer shows the level of fuel in the fuel tank when the ignition is in the ON/RUN position.



- The fuel pump symbol points to the side of the vehicle where the fuel door is located.

INSTRUMENT CLUSTER DISPLAY

Your vehicle is equipped with an instrument cluster display, which offers useful information to the driver. With the ignition in the OFF mode, opening/closing of a door will activate the display for viewing, and display the total miles, or kilometers, in the odometer. Your instrument cluster display is designed to display important information about your vehicle's systems and features. Using a driver interactive display located on the instrument panel, your instrument cluster display can show you how systems are working and give you warnings when they are not. The steering wheel mounted controls allow you to scroll through the main menus and submenus. You can access the specific information you want and make selections and adjustments.

INSTRUMENT CLUSTER DISPLAY CONTROLS

The instrument cluster display features a driver interactive display that is located in the instrument cluster.



Instrument Cluster Display/ Controls Location

- 1 – Instrument Cluster Display Screen
- 2 – Instrument Cluster Display Controls

DISPLAY MENU ITEMS

Push and release the **up** \triangle or **down** ∇ arrow button until the desired selectable menu icon is highlighted in the instrument cluster display.

Speedometer

Push and release the **up** \triangle or **down** ∇ arrow button until the speedometer menu item is highlighted in the instrument cluster display. Push and release the **OK** button to cycle the display between mph and km/h.

Speedometer options are as follows:

- Analog
 - Oil Pressure
 - Speedometer
 - Tire Pressure
- Digital
- Sport View



Sport Mode Cluster Screen

- Baja View
 - Gear
 - Speedometer
 - G-Force



Baja Mode Cluster Screen

Driver Assist — If Equipped

The Driver Assist menu displays the status of the ACC and LaneSense systems.

Push and release the **up** ▲ or **down** ▼ arrow button until the Driver Assist menu is displayed in the instrument cluster display.

Adaptive Cruise Control (ACC) Feature

The instrument cluster display displays the current Adaptive Cruise Control system settings. The information displayed depends on ACC system status.

Push the Adaptive Cruise Control on/off button (located on the steering wheel) until one of the following displays in the instrument cluster display:

Adaptive Cruise Control Off

When ACC is deactivated, the display will read “Adaptive Cruise Control Off”.

Adaptive Cruise Control Ready

When ACC is activated but the vehicle speed setting has not been selected, the display will read “Adaptive Cruise Control Ready”.

Push the SET + or the SET- button (located on the steering wheel) and the following will display in the instrument cluster display:

ACC SET

When ACC is set, the set speed will display in the instrument cluster.

The ACC screen may display once again if any ACC activity occurs, which may include any of the following:

- Distance Setting Change
- System Cancel
- Driver Override
- System Off
- ACC Proximity Warning
- ACC Unavailable Warning

LaneSense — If Equipped

The instrument cluster display displays the current LaneSense system settings. The information displayed depends on LaneSense system status and the conditions that need to be met.

Vehicle Info

Push and release the **up** ▲ or **down** ▼ arrow button until the Vehicle Info menu icon is displayed in the instrument cluster display. Push and release the **left** ◀ or **right** ▶ arrow button to scroll through the information submenus and push and release the **OK** button to select or reset the resettable submenus.

See the following table for gauges your vehicle may be equipped with:

Fuel Economy	Gauge Summary	Performance Summary
● Average Fuel Economy	● Coolant Temp	● Air Fuel
● Current Fuel Economy	● Trans Temp	● Engine Power
● Range To Empty	● Intake Air Temp	● Engine Torque
	● Intercooler Water Temp	● Boost Pressure

Oil Summary <ul style="list-style-type: none"> ● Oil Temperature ● Oil Life ● Oil Pressure 	Battery Voltage <ul style="list-style-type: none"> ● Storage Mode 	Tire Pressure Monitor System
Terrain Status <ul style="list-style-type: none"> ● Drive Mode 	Engine Hours	

Performance Features

Push and release the **up** ▲ or **down** ▼ arrow button until the Performance icon/title is highlighted in the instrument cluster display. Push and release the **left** ◀ or **right** ▶ arrow button to scroll through the performance feature submenu.

WARNING!

Measurement of vehicle statistics with the Performance Features is intended for off-highway or track use only and should not be done on any public roadways. It is recommended that these features be used in a controlled environment and within the limits of the law. The capabilities of the vehicle as measured by the performance pages must never be exploited in a reckless or dangerous manner, which can jeopardize the user's safety or the safety of others. Only a safe, attentive, and skillful driver can prevent accidents.

The Performance Features include the following:

Speed Timers	
0-60 MPH (0-100 km/h) Timer <ul style="list-style-type: none"> ● Best ● Last ● Current 	0-100 MPH (0-160 km/h) Timer <ul style="list-style-type: none"> ● Best ● Last ● Current

Drag Timers

0-60 feet (0-20 meters)/ Reaction Timer <ul style="list-style-type: none"> ● Best ● Last ● Current <p>NOTE: Reaction Time result is shown only on the 60 ft timer tab.</p>	0-330 feet (0-100 meters) Timer <ul style="list-style-type: none"> ● Best ● Last ● Current
1/8 Mile (200 meters) Timer <ul style="list-style-type: none"> ● Best ● Last ● Current 	0-1000 feet (0-300 meters) Timer <ul style="list-style-type: none"> ● Best ● Last ● Current ●
1/4 Mile (400 meters) Timer <ul style="list-style-type: none"> ● Best ● Last ● Current 	

Braking Distance

- Distance
- From Speed

G-Forces

- Current
- Peak

Lap Timer

- Current lap time

Lap History

- Will list the last five laps with the best lap highlighted in green.

Top Speed

- Top speed reached

Off Road

Push and release the **up** \triangle or **down** ∇ arrow button until the Off Road menu icon is displayed in the instrument cluster display. Push and release the **left** \triangleleft or **right** \triangleright arrow button to scroll through the information submenus.

- Drivetrain

- Front Wheel Angle: displays the graphical and numerical value of calculated average front wheel angle from the steering wheel orientation.
- Transfer Case Lock Status: displays “Lock” graphic only during 4WD Low status.
- Axle Lock Status: displays rear only axle locker graphic.

- Pitch And Roll

- Displays the pitch and roll of the vehicle in the graphic with the angle number on the screen.

NOTE:

When vehicle speed becomes too high to display the pitch and roll, “-” will display in place of the numbers, and the graphic will be greyed out. A message indicating the necessary speed for the feature to become available will also display.

- Wheel Articulation

- Displays the range of vertical height.
- When height is normal, axle half shaft is gray. When any level above or below normal, axle half shaft is yellow.
- When Min or Max wheel height is reached, the max/min vertical height level indicator will become yellow.

Diagnostics

Push and release the **up** \triangle or **down** ∇ arrow button until the Diagnostics icon/title is highlighted in the instrument cluster display. Push and release the **OK** button to display the diagnostic trouble codes and descriptions. When the end of the list is reached, “No or End of Diagnostic Code” will appear in the instrument cluster display.

Speed Warning

Push and release the **up** ▲ or **down** ▼ arrow button until the Speed Warning Menu icon/title is displayed in the instrument cluster display. Push and release **OK** to enter speed warning. Use the **up** ▲ or **down** ▼ arrow button to select a desired speed, then push and release **OK** to set the speed. The white passive speed limiter telltale will light up with a notification text message (Speed Warning Set to XX, followed by the selected unit). When the set speed is exceeded, an audible chime will sound until the speed is no longer exceeded. The white passive speed limiter telltale will turn yellow and will flash, and a pop-up message of “Speed Warning Exceeded” will display.

NOTE:

You can turn the Speed Warning off by using the **up** ▲ / **down** ▼ arrow button to scroll through speed list and select **OFF** at the bottom of the list.

Settings

Screen Setup Driver Selectable Items

Push and release the **up** ▲ or **down** ▼ arrow button until the Settings Menu Icon/Title is highlighted in the instrument cluster display. Push and release the **OK** button to enter the submenus and follow the prompts on the screen as needed. The Settings feature allows you to change what information is displayed in the instrument cluster as well as the location that information is displayed.

NOTE:

The Settings feature is only available when the vehicle speed is less than 5 mph (8 km/h).

Upper Left or Right		
None	Compass	Outside Temp
Time	Range	Average Econ
Current Econ	Trip A Distance	Trip B Distance
Trailer Trip – If Equipped	Trailer Brake – If Equipped	Oil Pressure
Coolant Temp	Battery Voltage	Oil Life
Oil Temperature	Transmission Temperature	

Favorite Menus		
Speedometer	Vehicle Info	Performance Show/Hide
Off Road Show/Hide	Driver Assist (show/hide) – If Equipped	Fuel Economy (show/hide)
Trip Info (show/hide)	Trailer Tow (show/hide)	Audio (show/hide)
Diagnostics	Settings	Messages (Stored)
Navigation		

Left and Right Side		
None	Transmission Temp	Oil Temp
Range To Empty	Coolant Temp	Menu Icon
Average Econ	Oil Life	

Lower Left and Right – If Equipped		
None	Compass	Outside Temp
Time	Range To Empty	Average Econ
Current Econ	Trip A Distance	Trip B Distance
Trailer Trip – If Equipped	Trailer Brake – If Equipped	Oil Pressure
Coolant Temperature	Oil Temperature	Battery Voltage
Transmission Temperature	Oil Life	

Current Gear

- Off (D)
- On (D1, D2, D3,...)

Odometer

- No Decimal Point
- Decimal Point
- Odometer Show/Hide

Fuel Gauge

- Hide Range
- Show Range

Defaults (Restores All Settings To Default Settings)

- Cancel
- Restore

HEAD UP DISPLAY (HUD) — IF EQUIPPED

NOTE:

The HUD feature Settings are available at any vehicle speed. Some information like speed limit or Driver Assist may not appear on the HUD unless your vehicle is equipped Traffic Sign Assist or Driver Assist systems.

Push and release the **up** \triangle or **down** ∇ arrow button until the Settings Menu icon/title is highlighted in the instrument cluster display. Push and release the **left** \triangleleft or **right** \triangleright arrow button until the HUD Menu icon/title is highlighted in the instrument cluster display. Push and release the **OK** button to enter HUD. Use the **up** \triangle or **down** ∇ arrow button to select a setting, then push and release the **OK** button to adjust the setting.

- ON/OFF

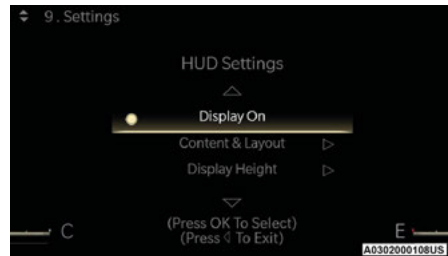

HUD ON/OFF

When “Display On” is selected, the HUD will display on the windshield. When it is not selected, no display on the windshield.

- Content and Layout
 - **Simple:** Speed, Speed Limit
 - **Standard:** Speed, Speed Limit, Navigation

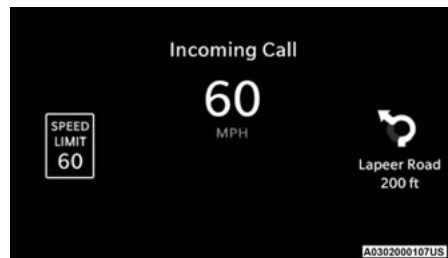

Standard Mode

- When “Standard” mode is selected, the HUD image is split into thirds with the speed limit indicator shown to the left, vehicle speed in the center, and turn-by-turn navigation to the right.
- **Advanced:** Speed, Speed Limit, Navigation, Driver Assist (ACC/Cruise, LaneSense, Highway Assist/Highway Assist+), Gear



Advanced Mode

When “Advanced” mode is selected, the HUD displays the vehicle speed, turn-by-turn navigation, speed limit, driver assist function(s), and current gear.

- **Custom 1:** Speed, Speed Limit
- **Custom 2:** Speed, Speed Limit, Navigation
- **Custom 3:** Speed, Speed Limit, Navigation, Driver Assist (ACC/Cruise, LaneSense, Highway Assist/Highway Assist+)

- **Custom 4:** Speed, Speed Limit, Navigation, Driver Assist (ACC/Cruise, LaneSense, Highway Assist/Highway Assist+), Gear
- **Sport View**
- **Baja View**
- Display Height
- Brightness



Expanded Example of HUD Display

NOTE:

The HUD basic settings (Brightness, Display Height and Non Custom layouts), are controlled through the Settings Screen in the Instrument Cluster ⇨ page 10.

TRX DRIVE MODE

Drive Mode Buttons

- 1 - Left Drive Mode Arrow
- 2 - Right Drive Mode Arrow

Push and release the **left** ◀ or **right** ▶ drive mode arrow button to change between the different Drive Modes. A pop-up will appear in the instrument cluster display to assist with choosing the desired drive mode. A drive mode status indicator will appear in the instrument cluster display ⇨ page 18. You can also double push on the TRX button to go directly to Custom Mode ⇨ page 55.

NOTE:

The selected drive mode will be applied once the instrument cluster pop-up times out due to lack of additional presses of the **left** ◀ or **right** ▶ arrow button ⇨ page 47.

WARNING LIGHTS AND MESSAGES

The warning/indicator lights will illuminate in the instrument panel together with a dedicated message and/or acoustic signal when applicable. These indications are indicative and precautionary and as such must not be considered as exhaustive and/or alternative to the information contained in the Owner's Manual, which you are advised to read carefully in all cases. Always refer to the information in this chapter in the event of a failure indication. All active telltales will display first if applicable. The system check menu may appear different based upon equipment options and current vehicle status. Some telltales are optional and may not appear.

DRIVE MODE INDICATOR LIGHTS

Sport Mode Indicator Light



This light will turn on when Sport mode is active → page 49.

Snow Mode Indicator Light



This light will turn on when Snow mode is active → page 50.

Tow Mode Indicator Light



This light will turn on when Tow mode is active → page 49.

Baja Mode Indicator Light



This light will turn on when Baja mode is active → page 54.

Mud/Sand Mode Indicator Light



This light will turn on when Mud/Sand mode is active → page 53.

Rock Mode Indicator Light



This light will turn on when Rock mode is active → page 53.

Custom Mode Indicator Light



This light will turn on when Custom mode is active → page 55.

Valet Mode Indicator Light



This light will turn on when Valet mode is active → page 65.

STARTING AND OPERATING

ENGINE BREAK-IN RECOMMENDATIONS

6.2L SUPERCHARGED ENGINE

The following tips will be helpful in obtaining optimum performance and maximum durability for your new vehicle.

Engine break-in occurs mainly during the first 500 miles (805 km) and continues through the first oil change interval.

It is recommended for the operator to observe the following driving behaviors during the break-in period:

0 to 100 miles (0 to 161 km):

- Do not allow the engine to operate at idle for an extended period of time.
- Press the accelerator pedal slowly and not more than halfway to avoid rapid acceleration.
- Avoid aggressive braking.
- Drive with the engine speed below 3,500 RPM.
- Maintain vehicle speed below 55 mph (88 km/h) and observe local speed limits.

100 to 300 miles (161 to 483 km):

- Press the accelerator pedal slowly and not more than halfway to avoid rapid acceleration in lower gears (FIRST to THIRD gears).
- Avoid aggressive braking.
- Drive with the engine speed below 5,000 RPM.
- Maintain vehicle speed below 70 mph (112 km/h) and observe local speed limits.

300 to 500 miles (483 to 805 km):

- Exercise the full engine RPM range, shifting manually (paddles or gear shift) at higher RPM when possible.
- Do not perform sustained operation with the accelerator pedal at wide open throttle.
- Maintain vehicle speed below 85 mph (136 km/h) and observe local speed limits.

For the first 1,500 miles (2,414 km):

- Do not participate in towing, high-speed off-roading or similar activities.

NOTE:

Check engine oil with every refueling and add if necessary. Oil and fuel consumption may be higher through the first oil change interval. Running the engine with an oil level below the add mark can cause severe engine damage.

AUTOMATIC TRANSMISSION

You must press and hold the brake pedal while shifting out of PARK.

WARNING!

- Never use the PARK position as a substitute for the parking brake. Always apply the parking brake fully when exiting the vehicle to guard against vehicle movement and possible injury or damage.
- Your vehicle could move and injure you and others if it is not in PARK. Check by trying to move the transmission gear selector out of PARK with the brake pedal released. Make sure the transmission is in PARK before exiting the vehicle.

(Continued)

WARNING!

- The transmission may not engage PARK if the vehicle is moving. Always bring the vehicle to a complete stop before shifting to PARK, and verify that the transmission gear position indicator solidly indicates PARK (P) without blinking. Ensure that the vehicle is completely stopped, and the PARK position is properly indicated, before exiting the vehicle.
- It is dangerous to shift out of PARK or NEUTRAL if the engine speed is higher than idle speed. If your foot is not firmly pressing the brake pedal, the vehicle could accelerate quickly forward or in reverse. You could lose control of the vehicle and hit someone or something. Only shift into gear when the engine is idling normally and your foot is firmly pressing the brake pedal.
- Unintended movement of a vehicle could injure those in or near the vehicle. As with all vehicles, you should never exit a vehicle while the engine is running. Before exiting a vehicle, always come to a complete stop, then apply the parking brake, shift the transmission into PARK, and turn the ignition OFF. When the ignition is in the OFF position, the transmission is locked in PARK, securing the vehicle against unwanted movement.

*(Continued)***WARNING!**

- When exiting the vehicle, always make sure the ignition is in the OFF position, remove the key fob from the vehicle, and lock the vehicle.
- Never leave children alone in a vehicle, or with access to an unlocked vehicle. Allowing children to be in a vehicle unattended is dangerous for a number of reasons. A child or others could be seriously or fatally injured. Children should be warned not to touch the parking brake, brake pedal or the transmission gear selector.
- Do not leave the key fob in or near the vehicle (or in a location accessible to children), and do not leave the ignition in the ACC or ON/RUN position. A child could operate power windows, other controls, or move the vehicle.

CAUTION!

- Shift into or out of PARK or REVERSE only after the vehicle has come to a complete stop.
- Do not shift between PARK, REVERSE, NEUTRAL, or DRIVE when the engine is above idle speed.
- Before shifting into any gear, make sure your foot is firmly pressing the brake pedal.

IGNITION PARK INTERLOCK

This vehicle is equipped with an Ignition Park Interlock which requires the transmission to be in PARK before the ignition can be turned to the OFF position. This helps the driver avoid inadvertently leaving the vehicle without placing the transmission in PARK. This system also locks the transmission in PARK whenever the ignition is in the OFF position.

NOTE:

The transmission will NOT shift out of the PARK position if the engine is not running even when the brakes are applied. Ensure that the transmission is in PARK, and the ignition is OFF (not in ACC position) before exiting the vehicle.

BRAKE/TRANSMISSION SHIFT INTERLOCK (BTSI) SYSTEM

This vehicle is equipped with a BTSI system that holds the transmission gear selector in PARK unless the brakes are applied. To shift the transmission out of PARK, the engine must be running and the brake pedal must be pressed.

The brake pedal must also be pressed to shift from NEUTRAL into DRIVE or REVERSE when the vehicle is stopped or moving at low speeds.

8-SPEED AUTOMATIC TRANSMISSION

The transmission gear range is displayed both beside the gear selector and in the instrument cluster. To select a gear range, push the lock button on the gear selector and move the selector rearward or forward. To shift the transmission out of PARK (P), the engine must be running and the brake pedal must be pressed. You must also press the brake pedal to shift from NEUTRAL (N) into DRIVE (D) or REVERSE (R) when the vehicle is stopped or moving at low speeds. Select the DRIVE range for normal driving.

NOTE:

- The transmission electronics are self-calibrating; therefore, the first few shifts on a new vehicle may be somewhat abrupt. This is a normal condition, and precision shifts will develop within a few hundred miles (kilometers).
- In the event of a mismatch between the gear selector position and the actual transmission gear (for example, driver selects PARK while driving), the position indicator will blink continuously until the selector is returned to the proper position, or the requested shift can be completed.

The electronically controlled transmission adapts its shift schedule based on driver inputs, along with environmental and road conditions.

Only shift from DRIVE to PARK or REVERSE when the accelerator pedal is released and the vehicle is stopped. Be sure to keep your foot on the brake pedal when shifting between these gears.

The transmission gear selector provides PARK, REVERSE, NEUTRAL, and SPORT (S) (AutoStick) shift positions. Manual shifts can be made using the AutoStick shift control. Toggling the gear selector forward (-) or rearward (+) while in the SPORT (AutoStick) position (beside the DRIVE position), or tapping the paddle shifters (+/-) (if equipped), will manually select the transmission gear, and will display the current gear in the instrument cluster ↷ page 23.



Gear Selector

NOTE:

If the gear selector cannot be moved to the PARK, REVERSE, or NEUTRAL position (when pushed forward), it is probably in the AutoStick (+/-) position (beside the DRIVE position). In AutoStick mode, the transmission gear (1, 2, 3, etc.) is displayed in the instrument cluster. Move the gear selector to the right (into the DRIVE position) for access to PARK, REVERSE, and NEUTRAL.

Gear Ranges

Do not press the accelerator pedal when shifting out of PARK or NEUTRAL.

NOTE:

After selecting any gear range, wait a moment to allow the selected gear to engage before accelerating. This is especially important when the engine is cold.

PARK (P)

This range supplements the parking brake by locking the transmission. The engine can be started in this range. Never attempt to use PARK while the vehicle is in motion. Apply the parking brake when exiting the vehicle in this range.

When parking on a hill, apply the parking brake before shifting the transmission to PARK. As an added precaution, turn the front wheels toward the curb on a downhill grade and away from the curb on an uphill grade.

When exiting the vehicle, always:

- Apply the parking brake
- Shift the transmission into PARK
- Turn the ignition OFF
- Remove the key fob from the vehicle

NOTE:

On four-wheel drive vehicles be sure that the transfer case is in a drive position.

CAUTION!

- DO NOT race the engine when shifting from PARK or NEUTRAL into another gear range, as this can damage the drivetrain.
- Before moving the gear selector out of PARK, you must start the engine, and also press the brake pedal. Otherwise, damage to the gear selector could result.

The following indicators should be used to ensure that you have properly engaged the transmission into the PARK position:

- When shifting into PARK, push the lock button on the gear selector and firmly move the selector all the way forward until it stops and is fully seated.

- Look at the transmission gear position display and verify that it indicates the PARK position (P), and is not blinking.
- With the brake pedal released, verify that the gear selector will not move out of PARK.

REVERSE (R)

This range is for moving the vehicle backward. Shift into REVERSE only after the vehicle has come to a complete stop.

NEUTRAL (N)

Use this range when the vehicle is standing for prolonged periods with the engine running. Apply the parking brake and shift the transmission into PARK if you must exit the vehicle.

WARNING!

Do not coast in NEUTRAL and never turn off the ignition to coast down a hill. These are unsafe practices that limit your response to changing traffic or road conditions. You might lose control of the vehicle and have a collision.

CAUTION!

Towing the vehicle, coasting, or driving for any other reason with the transmission in NEUTRAL can cause severe transmission damage. Refer to “Recreational Towing” in “Starting And Operating” in the Owner’s Manual for further information.

DRIVE (D)

This range should be used for most city and highway driving. It provides the smoothest upshifts and downshifts, and the best fuel economy. The transmission automatically upshifts through all forward gears.

When frequent transmission shifting occurs (such as when operating the vehicle under heavy loading conditions, in hilly terrain, traveling into strong head winds, or while towing a heavy trailer), use the AutoStick shift control to select a lower gear ⇨ page 23. Under these conditions, using a lower gear will improve performance and extend transmission life by reducing excessive shifting and heat buildup.

During extremely cold temperatures (-22°F [-30°C] or below), transmission operation may be modified depending on engine and transmission temperature as well as vehicle speed. Normal operation will resume once the transmission temperature has risen to a suitable level.

SPORT (S)

The SPORT (S, +/-) position (beside the DRIVE position) enables full manual control of transmission shifting (also known as AutoStick mode ↪ page 23). Toggling the gear selector forward (-) or rearward (+) while in the SPORT (AutoStick) position will manually select the transmission gear, and will display the current gear in the instrument cluster.

Transmission Limp Home Mode

Transmission function is monitored electronically for abnormal conditions. If a condition is detected that could result in transmission damage, Transmission Limp Home mode is activated. In this mode, the transmission may operate only in certain gears, or may not shift at all. Vehicle performance may be severely degraded and the engine may stall. In some situations, the transmission may not re-engage if the engine is turned off and restarted.

The Malfunction Indicator Light (MIL) may be illuminated. A message in the instrument cluster will inform the driver of the more serious conditions, and indicate what actions may be necessary.

In the event of a momentary problem, the transmission can be reset to regain all forward gears by performing the following steps:

NOTE:

In cases where the instrument cluster message indicates the transmission may not re-engage after engine shutdown, perform this procedure only in a desired location (preferably, at an authorized dealer).

1. Stop the vehicle.
2. Shift the transmission into PARK, if possible. If not, shift the transmission to NEUTRAL.
3. Push and hold the ignition switch until the engine turns off.
4. Wait approximately 30 seconds.
5. Restart the engine.
6. Shift into the desired gear range. If the problem is no longer detected, the transmission will return to normal operation.

NOTE:

Even if the transmission can be reset, we recommend that you visit an authorized dealer at your earliest possible convenience.

An authorized dealer has diagnostic equipment to assess the condition of your transmission. If the transmission cannot be reset, an authorized dealer service is required.

AutoStick

AutoStick is a driver-interactive transmission feature providing manual shift control, giving you more control of the vehicle. AutoStick allows you to maximize engine braking, eliminate undesirable upshifts and downshifts, and improve overall vehicle performance. This feature can also provide you with more control during passing, city driving, cold slippery conditions, mountain driving, trailer towing, and many other situations.

4



Paddle Shifters

- 1 – (-) Paddle
2 – (+) Paddle

Operation

In AutoStick mode, you can use the gear selector (in the SPORT position), or the paddle shifters, to manually shift the transmission. To activate AutoStick mode, move the gear selector into the SPORT (S) position (beside the DRIVE position), or tap one of the paddle shifters on the steering wheel. Tapping the (-) paddle shifter to enter AutoStick mode will downshift the transmission to the next lower gear, while tapping (+) to enter AutoStick mode will retain the current gear. The current transmission gear will be displayed in the instrument cluster.

NOTE:

The paddle shifters may be disabled (or re-enabled, as desired) using Drive Modes.

AutoStick mode has the following operational benefits:

- The transmission will automatically downshift as the vehicle slows (to prevent engine lugging) and will display the current gear.
- The transmission will automatically downshift to FIRST gear when coming to a stop. After a stop, the driver should manually upshift (+) the transmission as the vehicle is accelerated.

- You can start out, from a stop, in FIRST or SECOND gear (or THIRD gear, in 4WD LOW range, SNOW mode). Tapping (+) (at a stop) will allow starting in SECOND gear. Starting out in SECOND or THIRD gear can be helpful in snowy or icy conditions.
- If a requested downshift would cause the engine to overspeed, that shift will not occur.
- The system will ignore attempts to upshift at too low of a vehicle speed.
- Holding the (-) paddle pressed, or holding the gear selector in the (-) position, will downshift the transmission to the lowest gear possible at the current speed.
- Transmission shifting will be more noticeable when AutoStick is enabled.
- The system may revert to automatic shift mode if a fault or overheat condition is detected.

NOTE:

When Selec-Speed or Hill Descent Control is enabled, AutoStick is not active.

To disengage AutoStick, return the gear selector to the DRIVE position, or press and hold the (+) paddle shifter (and the gear selector is already in DRIVE) until "D" is once again indicated in the instrument cluster. You can shift in or out of AutoStick at any time without taking your foot off the accelerator pedal.

WARNING!

Do not downshift for additional engine braking on a slippery surface. The drive wheels could lose their grip and the vehicle could skid, causing a collision or personal injury.

FOUR-WHEEL DRIVE OPERATION

FOUR-POSITION ELECTRONICALLY SHIFTED TRANSFER CASE

This is an electronic shift transfer case and is operated by the 4WD Control Switch (Transfer Case Switch), which is located on the instrument panel.



Four-Position/On-Demand Transfer Case

This electronically shifted transfer case provides four positions:

- Four-Wheel Drive Automatic High Range (4WD AUTO)
- Four-Wheel Drive High Range (4WD HIGH)
- Four-Wheel Drive Low Range (4WD LOW)
- N (Neutral)

For additional information on the appropriate use of each transfer case position, see the following:

4WD AUTO

Four-Wheel Drive Auto High Range — This range always sends power to the front wheels and automatically adjusts the front and rear torque split to optimize performance for the operating conditions. For example, when the vehicle senses a loss of traction. This range may be used during varying road conditions.

4WD HIGH

Four-Wheel Drive High Range — This range provides torque to the front driveshaft (engages four-wheel drive) which allows front and rear wheels to spin at the same speed. This provides additional traction for loose or slippery road surfaces only. The use of 4WD HIGH on dry paved surfaces will increase tire wear and may cause damage to driveline components.

4WD LOW

Four-Wheel Drive Low Range — This range provides low-speed four-wheel drive. It maximizes torque (increased torque over 4WD HIGH) to the driveline; allowing front and rear wheels to rotate at the same speed. This range provides additional traction and maximum pulling power for loose or slippery road surfaces only. Do not exceed 55 mph (88 km/h) in this range.

The use of 4WD LOW on dry paved surfaces will increase tire wear and may cause damage to driveline components.

N (Neutral)

WARNING!

- You or others could be injured or killed if you leave the vehicle unattended with the transfer case in the N (Neutral) position without first fully engaging the parking brake. The transfer case N (Neutral) position disengages both the front and rear drive shaft from the powertrain, and will allow the vehicle to roll, even if the transmission is in PARK. The parking brake should always be applied when the driver is not in the vehicle.
- The transmission may not engage PARK if the vehicle is moving. Always bring the vehicle to a complete stop before shifting to PARK, and verify that the transmission gear position indicator solidly indicates PARK (P) without blinking. Ensure that the vehicle is completely stopped, and the PARK position is properly indicated, before exiting the vehicle.

This electronically shifted transfer case is designed to be driven in the four-wheel drive auto position (4WD AUTO) for normal street and highway conditions on dry, hard surfaced roads.

When additional traction is required, the transfer case 4WD HIGH and 4WD LOW positions can be used to maximize torque to the front driveshaft, forcing the front and rear wheels to rotate at the same speed. This is accomplished pushing the desired position on the 4WD Control Switch.

For specific shifting instructions ⇨ page 27.

The 4WD HIGH and 4WD LOW positions are designed for loose, slippery road surfaces only. Driving in the 4WD HIGH and 4WD LOW positions on dry, hard surfaced roads may cause increased tire wear and damage to the driveline components.

NOTE:

The transfer case N (Neutral) button is located in the center of the 4WD Control Switch and is pushed by using a ballpoint pen or similar object. The transfer case N (Neutral) position is to be used for recreational towing only. Refer to “Recreational Towing” in “Starting And Operating” in the Owner’s Manual for further information.

Transfer Case Position Indicator Lights

The Transfer Case Position Indicator Lights (4WD HIGH and 4WD LOW) are located in the instrument cluster and indicate the current and desired transfer case selection. When you select a different transfer case position, the indicator lights will do the following:

1. The current position indicator light will turn off.
2. The selected position indicator light will flash until the transfer case completes the shift.
3. When the shift is complete, the indicator light for the selected position will stop flashing and remain on.

If the transfer case does not shift into the desired position, one or more of the following events may occur:

1. The indicator light for the current position will remain on.
2. The newly selected position indicator light will continue to flash.
3. If the transfer case **will not** shift, there will be a cluster message stating the 4WD shift has canceled.

NOTE:

Before retrying a selection, make certain that all the necessary requirements for selecting a new transfer case position have been met. To retry the selection, push the current position, wait five seconds, and retry selection. To find the shift requirements ⇨ page 27.

The SERV 4WD Warning Light monitors the electronic shift four-wheel drive system. If this light remains on after engine start-up or illuminates during driving, it means that the four-wheel drive system is not functioning properly and that service is required.

WARNING!

Always engage the parking brake when powering down the vehicle if the SERV 4WD Warning Light is illuminated. Not engaging the parking brake may allow the vehicle to roll which may cause personal injury or death.

NOTE:

Do not attempt to make a shift while only the front or rear wheels are spinning. This could cause damage to driveline components.

When operating your vehicle in 4WD LOW, the engine speed is approximately three times that of the 4WD AUTO or 4WD HIGH positions at a given road speed. Take care not to overspeed the engine and do not exceed 55 mph (88 km/h).

Proper operation of four-wheel drive vehicles depends on tires of equal size, type and circumference on each wheel. Any difference in tire size can cause damage to the drivetrain.

Because four-wheel drive provides improved traction, there is a tendency to exceed safe turning and stopping speeds. Do not go faster than road conditions permit.

Shifting Procedure

NOTE:

- If any of the requirements to select a new transfer case position have not been met, the transfer case will not shift. The position indicator light for the previous position will remain on and the newly selected position indicator light will continue to flash until all the requirements for the selected position have been met.
- If all the requirements to select a new transfer case position have been met, the current position indicator light will turn off, the selected position indicator light will flash until the transfer case completes the shift. When the shift is complete, the position indicator light for the selected position will stop flashing and remain on.

SELEC-SPEED CONTROL (SSC)



Selec-Speed Control Button

SSC is intended for off-road driving in 4WD LOW only. SSC maintains vehicle speed by actively controlling engine torque and brakes.

NOTE:

For vehicles not equipped with Trailer Reverse Steering Control (TRSC), your SSC button is located on the Auxiliary Switch Bank below your radio screen.

SSC has three states:

1. Off (feature is not enabled and will not activate)

2. Enabled (feature is enabled and ready but activation conditions are not met, or driver is actively overriding with brake or throttle application)
3. Active (feature is enabled and actively controlling vehicle speed)

Enabling SSC

SSC is enabled by pushing the SCC button when the following conditions are met:

- The driveline is in 4WD LOW.
- The vehicle speed is below 5 mph (8 km/h).
- The parking brake is released.
- The driver door is closed.
- The driver is not applying throttle.

Activating SSC

Once SSC is enabled it will activate automatically once the following conditions are met:

- The driver releases the throttle.
- The driver releases the brake.
- The transmission is in any selection other than PARK.
- Your vehicle speed is below 20 mph (32 km/h).

The set speed for SSC is selectable by the driver, and can be adjusted by using the paddle shifters or the gear shift (+/-) on the steering wheel. Additionally, the SSC set speed may be reduced when climbing a grade and the level of set speed reduction depends on the magnitude of grade. The following summarizes the SSC set speeds:

SSC Target Set Speeds

- 1st = 0.6 mph (1 km/h)
- 2nd = 1.2 mph (2 km/h)
- 3rd = 1.8 mph (3 km/h)
- 4th = 2.5 mph (4 km/h)
- 5th = 3.1 mph (5 km/h)
- 6th = 3.7 mph (6 km/h)
- 7th = 4.3 mph (7 km/h)
- 8th = 5 mph (8 km/h)
- REVERSE = 0.6 mph (1 km/h)
- NEUTRAL = 1.2 mph (2 km/h)
- PARK = SSC remains enabled but not active

NOTE:

- During SSC, the (+/-) gear selector input is used for SSC target speed selection but will not affect the gear chosen by the transmission. While actively controlling SSC, the transmission will shift appropriately for the driver-selected set speed and corresponding driving conditions.
- SSC operation is influenced if one of the drive modes are active. The differences may be notable to the driver as a varying level of aggressiveness.

Driver Override

The driver may override SSC activation with throttle or brake application at any time.

Deactivating SSC

SSC will be deactivated but remain available if any of the following conditions occur:

- The driver overrides SSC set speed with throttle or brake application.
- The vehicle speed exceeds 20 mph (32 km/h) but remains below 40 mph (64 km/h).
- The vehicle is shifted into PARK.

Disabling SSC

SSC will deactivate and be disabled if any of the following conditions occur:

- The driver pushes the SSC button.
- The driveline is shifted out of the 4WD LOW.
- The parking brake is applied.
- The driver door opens.
- The vehicle is driven greater than 20 mph (32 km/h) for greater than 70 seconds.
- The vehicle is driven greater than 40 mph (64 km/h). SSC will exist immediately.

Feedback To The Driver

The instrument cluster has an SSC icon and the SSC switch has a lamp which offers feedback to the driver about the state SSC is in.

- The cluster icon and switch lamp will illuminate and remain on solid when SSC is enabled or activated. These are the normal operating conditions for SSC.
- The cluster icon and switch lamp will flash for several seconds then extinguish when the driver pushes the SSC switch but enabled conditions are not met.

- The cluster icon and switch lamp will flash for several seconds then extinguish when SSC disables due to excess speed.
- The cluster icon and switch lamp will flash then extinguish when SSC deactivates due to over-heated brakes.

WARNING!

SSC is only intended to assist the driver in controlling vehicle speed when driving in off-road conditions. The driver must remain attentive to the driving conditions and is responsible for maintaining a safe vehicle speed.

TRX MODES

Description

TRX modes combine the capabilities of the vehicle control systems, along with driver input, to provide the best performance for all terrains.

Use the TRX button and selection arrows to select the desired mode.



TRX Button

- 1 – TRX Button
- 2 – Right Arrow
- 3 – Left Arrow

TRX modes consist of the following positions:

- **AUTO** – This mode is intended for typical on-road driving with default settings.
- **SNOW** – This mode maximizes traction and stability with equal torque split between the front and rear wheels. The transmission defaults to early shifting and engine throttle response is softened to reduce wheel slip. SNOW mode is only meant to assist and is not a replacement for safe driving practices during inclement weather. This feature will reset to AUTO upon an ignition cycle if not in 4WD LOW.

- **TOW** – This mode minimizes transmission gear changes and adapts the suspension for towing or hauling heavy loads. Drive torque is more evenly split between the front and rear wheels for improved traction. This feature will reset to AUTO upon an ignition cycle if not in 4WD LOW.
- **SPORT** – This mode improves handling capability through front and rear torque split and increased suspension control. The transmission delivers quicker, firmer shifts. Steering force is increased for improved feedback and control. This feature will reset to AUTO on an ignition cycle. SPORT mode is not available while in 4WD LOW.
- **CUSTOM** – This mode allows the driver to create a custom vehicle configuration that is saved for quick selection of favorite settings. The system will return to AUTO mode when the ignition switch is cycled from RUN to OFF to RUN, if this mode is selected. While in CUSTOM mode the Stability, Transmission, Steering, Suspension, and paddle shifter settings may be configured through the custom mode set-up. This feature will reset to AUTO on an ignition cycle if not in 4WD LOW.

- **MUD/SAND** – This mode maximizes traction with equal torque split front and rear. Traction control intervention is reduced to allow for peak performance on mud or sand. This feature will reset to AUTO on an ignition cycle if not in 4WD LOW.
- **ROCK** – This mode maximizes rock crawling competency by increasing torque at the wheels by using 4WD LOW mode. Steering and throttle are tuned for low speed driving. This mode can only be used at speeds below 30 mph (48 km/h).
- **BAJA** – This mode provides ideal transmission shifting to keep the engine in power band for best performance. Driveline, steering, and suspension actively adjust for optimal vehicle dynamic behavior on varying terrain. This feature will reset to AUTO on an ignition cycle. BAJA mode is not available while in 4WD LOW.

For further information and description

➤ page 47.

Adaptive Damping System

This vehicle is equipped with an electronically controlled damping system. This system reduces body roll and pitch in many driving situations including cornering, acceleration and braking. There are three modes:

- **Street Mode** (Available in drive mode positions AUTO, SNOW and CUSTOM.) – Used during highway speeds where a touring suspension feel is desired.
- **Sport Mode** (Available in drive mode positions SPORT, TOW, AUTO and CUSTOM.) – Provides a firm suspension for better handling on-road.
- **Baja Mode** (Available in drive mode positions AUTO, CUSTOM, MUD/SAND, ROCK and BAJA.) – Optimized for high-speed off-road driving.

Launch Control

This vehicle is equipped with a Launch Control system that is designed to allow the driver to achieve maximum vehicle acceleration in a straight line. Launch Control is a form of traction control that manages tire slip while launching the vehicle. This feature is intended for off-highway use where maximum acceleration is desired. The system is not intended to compensate for lack of driver experience or familiarity with the terrain.

Use of this feature in low traction (cold, wet, gravel, etc.) conditions may result in excess wheel slip outside this system's control resulting in an aborted launch.

NOTE:

Launch control allows you to select the best launch for vehicle, environmental, and traction conditions. When using this feature, start at a lower RPM launch setting and increment the RPM on subsequent launches until the best launch is experienced.

Preconditions:

- Launch Control should not be used on public roads. Always check surface conditions and the surrounding area.
- Launch Control is not available within the first 500 miles (805 km) of engine break-in.
- Launch Control should only be used when the engine and transmission are at operating temperature.

- Launch Control is intended to be used on dry, paved road surfaces only.

CAUTION!
Use on slippery or loose surfaces may cause damage to vehicle components and is not recommended.

- Launch Control is not available while operating in 4WD LOW.

Launch Control is only available when the following procedure is followed:

NOTE:

Pushing the TRX button on the control switch or pressing the Apps button on the touchscreen are the two options to access Launch Control features ↪ page 47.

1. Press the Race Options button on the touchscreen.
2. Press the Launch Control button on the touchscreen. This screen will allow you to adjust your launch RPM for optimum launch/traction.

3. Push the LAUNCH button on the TRX control switch or press the Activate Launch Control button on the touchscreen; follow instructions in the instrument cluster display.
 - Make sure the vehicle is not moving
 - Put vehicle in FIRST gear or DRIVE
 - Steering wheel must be pointing straight
 - Vehicle must be on level ground
 - Apply brake pressure
 - While holding the brake, rapidly apply and hold the accelerator pedal to wide open throttle. The engine speed will hold at the RPM that was set in the Launch RPM Set-up screen

NOTE:

Messages will appear in the instrument cluster display to inform the driver if one or more of the above conditions have not been met.

4. When the above conditions have been met, the instrument cluster display will read "Release Brake".
5. Keep the vehicle pointed straight.

Launch control will be active until the vehicle reaches 62 mph (100 km/h), at which point the Electronic Stability Control (ESC) system will return to its current ESC mode as well as previous drive mode.

Launch Control will abort before launch completion and display a "Launch Aborted" message in the instrument cluster when any of the following occur:

- The accelerator pedal is released during launch.
- The ESC system detects that the vehicle is no longer moving in a straight line.
- The ESC OFF button is pushed to change the system to another mode.

CAUTION!
Do not attempt to shift when the drive wheels are spinning and do not have traction. Damage to the transmission may occur.

AXLE LOCKER SYSTEM

This vehicle is equipped with an electronically locking rear differential. This differential, when engaged, mechanically lock together the axle shafts forcing the wheels to spin at an equal rate. The locking of the rear differential should only be engaged during low-speed, extreme off-road situations where one wheel is likely to not be in contact with the ground. It is not recommended to drive the vehicle with the differential locked on pavement due to the reduced ability to turn and speed limitations.



AXLE LOCK Button

CAUTION!

- Do not lock the rear axle on hard surfaced roads. The ability to steer the vehicle is reduced and damage to the drivetrain may occur when the axle is locked on hard surfaced roads.
- Do not try to lock the rear axle if the vehicle is stuck and the tires are spinning. You can damage drivetrain components. Lock the rear axle before attempting situations or navigating terrain, which could possibly cause the vehicle to become stuck.

The locking rear axle is controlled by the AXLE LOCK button.

Under normal driving conditions, the rear axle should be unlocked.

During the command to lock the rear axle, the indicator light will flash until the axle is locked. After the lock command has been successfully executed, the light will remain solid.

Operating in 4WD LOW the locker can be engaged up to 40 mph (64 km/h) and will remain engaged throughout the 4WD LOW speed range.

Operating the locker in 4WD AUTO and 4WD HIGH, the locker can be engaged up to 20 mph (32 km/h). It will remain engaged throughout the entire 4WD speed range.

NOTE:

Left to right wheel speed difference may be necessary to allow the rear axle to fully lock. If the indicator light is flashing after selecting the rear axle lock mode, drive the vehicle in a turn or on loose gravel to expedite the locking action.

The axle locker could become torque locked due to side to side loads on the rear axle. Driving slowly while turning the steering wheel from a left hand turn to a right hand turn or driving in REVERSE for a short distance may be required to release the torque lock and unlock the axles.

To unlock the rear axle; push the AXLE LOCK button. The AXLE LOCK indicator light will go out when the rear axle is unlocked.

DRIVING TIPS

ON-ROAD DRIVING TIPS

Off-road trucks have higher ground clearance and increased suspension travel to make them capable of performing in a wide variety of off-road applications. Specific design characteristics give them a higher center of gravity than conventional passenger cars.

An advantage of the higher ground clearance is a better view of the road, allowing you to anticipate problems. They are not designed for cornering at the same speeds as conventional passenger cars any more than low-slung sports cars are designed to perform satisfactorily in off-road conditions. Avoid sharp turns or abrupt maneuvers. As with other vehicles of this type, failure to operate this vehicle correctly may result in loss of control or vehicle rollover.

OFF-ROAD DRIVING TIPS

The Basics Of Off-Road Driving

You will encounter many types of terrain driving off-road. You should be familiar with the terrain and area before proceeding. There are many types of surface conditions: hard-packed dirt, gravel, rocks, grass, sand, mud, snow and ice. Every surface has a different affect on your vehicle's steering, handling and traction. Controlling your vehicle is one of the keys to

successful off-road driving, so always keep a firm grip on the steering wheel and maintain a good driving posture. Avoid sudden accelerations, turns or braking. In most cases, there are no road signs, posted speed limits or signal lights. Therefore, you will need to use your own good judgment on what is safe and what is not. When on a trail, you should always be looking ahead for surface obstacles and changes in terrain. The key is to plan your future driving route while remembering what you are currently driving over.

WARNING!

Always wear your seat belt and firmly tie down cargo. Unsecured cargo can become projectiles in an off-road situation.

CAUTION!

Never park your vehicle over dry grass or other combustible materials. The heat from your vehicle exhaust system could cause a fire.

When To Use 4WD LOW

When off-road driving, shift into 4WD LOW for additional traction and control on slippery or difficult terrain, ascending or descending steep hills, and to increase low speed pulling power. This range should be limited to extreme situations such as deep snow, mud, steep inclines, or sand where additional low speed pulling power is needed. Vehicle speeds in excess of 55 mph (88 km/h) should be avoided when in 4WD LOW.

CAUTION!

Do not use 4WD LOW when operating the vehicle on dry pavement. Driveline hardware damage can result.

Simultaneous Brake And Throttle Operation

Many off-road driving conditions require the simultaneous use of the brake and throttle (two-footed driving). When climbing rocks, logs, or other stepped objects, using light brake pressure with light throttle will keep the vehicle from jerking or lurching. This technique is also used when you need to stop and restart a vehicle on a steep incline.

Driving In Snow, Mud And Sand

SNOW

In heavy snow or for additional control and traction at slower speeds, select SNOW mode from the TRX modes. This will optimize traction and stability in these conditions. Do not shift to a lower gear than necessary to maintain headway. Over-revving the engine can spin the wheels and traction will be lost. If you start to slow to a stop, try turning your steering wheel no more than a quarter turn quickly back and forth, while still applying throttle. This will allow the tires to get fresh traction and help maintain your momentum.

CAUTION!

On icy or slippery roads, do not downshift at high engine RPM or vehicle speeds, because engine braking may cause skidding and loss of control.

MUD

Deep mud creates a great deal of suction around the tires and is very difficult to get through. Select SAND/MUD mode from the TRX modes for optimum traction and maneuverability in these conditions. If you start to slow to a stop, try turning your steering wheel no more than a quarter turn quickly back and forth for additional traction. Mud holes pose an increased threat of vehicle damage and getting stuck. They are normally full of debris from previous vehicles getting stuck. As a good practice before entering any mud hole, get out and determine how deep it is, if there are any hidden obstacles and if the vehicle can be safely recovered if stuck.

SAND

Select MUD/SAND from the TRX modes. Soft sand is very difficult to travel through with full tire pressure. When crossing soft, sandy spots in a trail, maintain your vehicle's momentum and do not stop. The key to driving in soft sand is using the appropriate tire pressure, accelerating slowly, avoiding abrupt maneuvers and maintaining the vehicle's momentum. If you are going to be driving on large soft sandy areas or dunes, reduce your tire pressure to a minimum of 15 psi (103 kPa) to allow for a greater tire surface area. Reduced tire pressure will drastically improve your traction and handling while driving on the soft sand, but you must return the tires to normal air pressure before driving on pavement or other hard surfaces. Be sure you have a way to reinflate the tires prior to reducing the pressure.

CAUTION!

Reduced tire pressures may cause tire unseating and total loss of air pressure. To reduce the risk of tire unseating, while at a reduced tire pressure, reduce your speed and avoid sharp turns or abrupt maneuvers. The optionally available Beadlock wheels are recommended to avoid unseating the tire from the wheel when running very low tire pressures.

Crossing Obstacles (Rocks And Other High Points)

While driving off-road, you will encounter many types of terrain. These varying types of terrain bring different types of obstacles. Before proceeding, review the path ahead to determine the correct approach and your ability to safely recover the vehicle if something goes wrong. Keeping a firm grip on the steering wheel, bring the vehicle to a complete stop and then inch the vehicle forward until it makes contact with the object. Apply the throttle lightly while holding a light brake pressure and ease the vehicle up and over the object.

WARNING!

Crossing obstacles can cause abrupt steering system loading which could cause you to lose control of your vehicle.

USING A SPOTTER

There are many times where it is hard to see the obstacle or determine the correct path. Determining the correct path can be extremely difficult when you are confronting many obstacles. In these cases have someone guide you over, through, or around the obstacle. Have the person stand a safe distance in front of you where they can see the obstacle, watch your tires and undercarriage, and guide you through.

CROSSING LARGE ROCKS

When approaching large rocks, choose a path which ensures you drive over the largest of them with your tires. This will lift your undercarriage over the obstacle. The tread of the tire is tougher and thicker than the side wall and is designed to take the abuse. Always look ahead and make every effort to cross the large rocks with your tires.

CAUTION!

- Never attempt to straddle a rock that is large enough to strike your axles or undercarriage.
- Never attempt to drive over a rock which is large enough to contact the door sills.

CROSSING A RAVINE, GULLY, DITCH, WASHOUT OR RUT

When crossing a ravine, gully, ditch, washout or a large rut, the angled approach is the key to maintaining your vehicle's mobility. Approach these obstacles at a 45-degree angle and let each tire go through the obstacle independently. You need to use caution when crossing large obstacles with steep sides. Do not attempt to cross any large obstacle with steep sides at an angle great enough to put the vehicle at risk of a rollover. If you get caught in a rut, dig a small trench to the right or left at a 45-degree angle ahead of the front tires.

Use the removed dirt to fill the rut ahead of the turnout you just created. You should now be able to drive out following the trench you just created at a 45-degree angle.

WARNING!

There is an increased risk of rollover when crossing an obstacle, at any angle, with steep sides.

CROSSING LOGS

To cross a log, approach it at a slight angle (approximately 10 to 15 degrees). This allows one front tire to be on top of the log while the other just starts to climb the log. While climbing the log, modulate your brake and accelerator to avoid spinning the log out from under your tires. Then ease the vehicle off the log using your brakes.

CAUTION!

Do not attempt to cross a log with a greater diameter than the running ground clearance or the vehicle will become high-centered.

GETTING HIGH-CENTERED

If you get hung up or high-centered on an object, get out of the vehicle and try to determine what the vehicle is hung up on, where it is contacting the underbody and what is the best direction to recover the vehicle. Depending on what you are in contact with, jack the vehicle up and place a few rocks under the tires so the weight is off of the high point when you let the vehicle down. You can also try rocking the vehicle or winching the vehicle off the object.

CAUTION!

Winching or rocking the vehicle off hard objects increases the risk of underbody damage.

Hill Climbing

Hill climbing requires good judgment and a good understanding of your abilities and your vehicle's limitations. Hills can cause serious problems. Some are just too steep to climb and should not be attempted. You should always feel confident with the vehicle and your abilities. You should always climb hills straight up and down. Never attempt to climb a hill on an angle.

BEFORE CLIMBING A STEEP HILL

As you approach a hill, consider its grade or steepness. Determine if it is too steep. Look to see what the traction is on the hill side trail. Is the trail straight up and down? What is on top and the other side? Are there ruts, rocks, branches or other obstacles on the path? Can you safely recover the vehicle if something goes wrong? If everything looks good and you feel confident, shift the transmission into a lower gear with 4WD LOW engaged, and proceed with caution, maintaining your momentum as you climb the hill.

DRIVING UPHILL

Once you have determined your ability to proceed and have shifted into the appropriate gear, line your vehicle up for the straightest possible run. Accelerate with an easy constant throttle and apply more power as you start up the hill. Do not race forward into a steep grade; the abrupt change of grade could cause you to lose control. If the front end begins to bounce, ease off the throttle slightly to bring all four tires back on the ground. As you approach the crest of the hill, ease off the throttle and slowly proceed over the top. If the wheels start to slip as you approach the crest of a hill, ease off the accelerator and maintain headway by turning the steering wheel no more than a quarter turn quickly back and forth. This will provide a fresh "bite" into the surface and will usually provide enough traction to complete the climb. If you do not make it to the top, place the vehicle in REVERSE and back straight down the grade using engine resistance along with the vehicle brakes.

WARNING!

Never attempt to climb a hill at an angle or turn around on a steep grade. Driving across an incline increases the risk of a rollover, which may result in severe injury.

DRIVING DOWNHILL

Before driving down a steep hill, you need to determine if it is too steep for a safe descent. What is the surface traction? Is the grade too steep to maintain a slow, controlled descent? Are there obstacles? Is it a straight descent? Is there plenty of distance at the base of the hill to regain control if the vehicle descends too fast? If you feel confident in your ability to proceed, then make sure you are in 4WD LOW and proceed with caution. Allow engine braking to control the descent and apply your brakes, if necessary, but do not allow the tires to lock.

WARNING!

Do not descend a steep grade in NEUTRAL. Use vehicle brakes in conjunction with engine braking. Descending a grade too fast could cause you to lose control and be seriously injured or killed.

DRIVING ACROSS AN INCLINE

If at all possible, avoid driving across an incline. If it is necessary, know your vehicle's abilities. Driving across an incline places more weight on the downhill wheels, which increases the possibility of a downhill slide or rollover. Make sure the surface has good traction with firm and stable soils. If possible, transverse the incline at an angle heading slightly up or down.

WARNING!

Driving across an incline increases the risk of a rollover, which may result in severe injury.

IF YOU STALL OR BEGIN TO LOSE HEADWAY

If you stall or begin to lose headway while climbing a steep hill, allow your vehicle to come to a stop and immediately apply the brake. Restart the engine and shift into REVERSE. Back slowly down the hill allowing engine braking to control the descent and apply your brakes, if necessary, but do not allow the tires to lock.

WARNING!

If the engine stalls or you lose headway or cannot make it to the top of a steep hill or grade, never attempt to turn around. To do so may result in tipping and rolling the vehicle, which may result in severe injury. Always back carefully straight down a hill in REVERSE. Never back down a hill in NEUTRAL using only the vehicle brakes. Never drive diagonally across a hill, always drive straight up or down.

4

Driving Through Water

Extreme care should be taken crossing any type of water. Water crossings should be avoided, if possible, and only be attempted when necessary in a safe, responsible manner. Only drive through areas which are designated and approved. Tread lightly and avoid damage to the environment. Know your vehicle's abilities and be able to recover it if something goes wrong. Never stop or shut a vehicle off when crossing deep water unless you ingested water into the engine air intake. If the engine stalls, do not attempt to restart it. Determine if it has ingested water first. The key to any crossing is low and slow.

Shift into DRIVE, with the transfer case in the 4WD LOW position and proceed very slowly with a constant slow speed of (3 to 5 mph [5 to 8 km/h] maximum) and light throttle. Keep the vehicle moving; do not try to accelerate through the crossing. After crossing any water higher than the bottom of the axle differentials, inspect all of the vehicle fluids for signs of water ingestion.

CAUTION!

- Water ingestion into the axles, transmission, transfer case, engine or vehicle interior can occur if you drive too fast or through too deep of water. Water can cause permanent damage to engine, driveline or other vehicle components, and your brakes will be less effective once wet and/or muddy.
- When driving through water, do not exceed 5 mph (8 km/h). Always check water depth before entering as a precaution, and check all fluids afterward. Driving through water may cause damage that may not be covered by the New Vehicle Limited Warranty.

BEFORE YOU CROSS ANY TYPE OF WATER

As you approach any type of water, you need to determine if you can cross it safely and responsibly. If necessary, get out and walk through the water or probe it with a stick. You need to be sure of its depth, approach angle, current and bottom condition. Be careful of murky or muddy waters; check for hidden obstacles. Make sure you will not be intruding on any wildlife, and you can recover the vehicle if necessary. The key to a safe crossing is the water depth, current and bottom conditions. On soft bottoms, the vehicle will sink in, effectively increasing the water level on the vehicle. Be sure to consider this when determining the depth and the ability to safely cross.

CROSSING PUDDLES, POOLS, FLOODED AREAS OR OTHER STANDING WATER

Puddles, pools, flooded or other standing water areas normally contain murky or muddy waters. These water types normally contain hidden obstacles and make it difficult to determine an accurate water depth, approach angle, and bottom condition. Murky or muddy water holes are where you want to hook up tow straps prior to entering.

This makes for a faster, cleaner and easier vehicle recovery. If you are able to determine you can safely cross, then proceed using the low and slow method.

CAUTION!

Muddy waters can reduce the cooling system effectiveness by depositing debris onto the radiator.

CROSSING DITCHES, STREAMS, SHALLOW RIVERS OR OTHER FLOWING WATER

Flowing water can be extremely dangerous. Never attempt to cross a fast running stream or river even in shallow water. Fast moving water can easily push your vehicle downstream, sweeping it out of control. Even in very shallow water, a high current can still wash the dirt out from around your tires putting you and your vehicle in jeopardy. There is still a high risk of personal injury and vehicle damage with slower water currents in depths greater than the vehicle's running ground clearance. You should never attempt to cross flowing water which is deeper than the vehicle's running ground clearance.

Even the slowest current can push the heaviest vehicle downstream and out of control if the water is deep enough to push on the large surface area of the vehicle's body. Before you proceed, determine the speed of the current, the water's depth, approach angle, bottom condition and if there are any obstacles. Then cross at an angle heading slightly upstream using the low and slow technique.

WARNING!

Never drive through fast moving deep water. It can push your vehicle downstream, sweeping it out of control. This could put you and your passengers at risk of injury or drowning.

After Driving Off-Road

Off-road operation puts more stress on your vehicle than does most on-road driving. After going off-road, it is always a good idea to check for damage. That way you can get any problems taken care of right away and have your vehicle ready when you need it.

- Completely inspect the underbody of your vehicle. Check tires, body structure, steering, suspension, and exhaust system for damage.
- Inspect the radiator for mud and debris and clean as required.
- Check threaded fasteners for looseness, particularly on the chassis, drivetrain components, steering, and suspension. Retighten them, if required, and torque to the values specified in the Service Manual.
- Check for accumulations of plants or brush. These things could be a fire hazard. They might hide damage to fuel lines, brake hoses, axle pinion seals, and propeller shafts.

- After extended operation in mud, sand, water, or similar dirty conditions, have the radiator, fan, brake rotors, wheels, brake linings, and axle yokes inspected and cleaned as soon as possible.

WARNING!

Abrasive material in any part of the brakes may cause excessive wear or unpredictable braking. You might not have full braking power when you need it to prevent a collision. If you have been operating your vehicle in dirty conditions, get your brakes checked and cleaned as necessary.

- If you experience unusual vibration after driving in mud, slush or similar conditions, check the wheels for impacted material. Impacted material can cause a wheel imbalance and freeing the wheels of it will correct the situation.

MULTIMEDIA

PERFORMANCE PAGES

Performance Pages is an application that provides a display for performance indicators that will help you gain familiarity with the capabilities of your vehicle in real time.

To access the Performance Pages, press the Vehicle button on the touchscreen. Then, press the SRT tab. Press the desired button on the touchscreen to access “Performance Pages”, “Drive Modes”, or “Race Options”.

WARNING!

Measurement of vehicle statistics with the Performance Pages is intended for off-highway or off-road use only and should not be done on any public roadways. It is recommended that these features be used in a controlled environment and within the limits of the law. The capabilities of the vehicle as measured by the Performance Pages must never be exploited in a reckless or dangerous manner, which can jeopardize the user’s safety or the safety of others. Only a safe, attentive, and skillful driver can prevent accidents.

The Performance Pages include the following:

- Timers
- Gauges
- G-Force
- Dyno/Engine
- Vehicle Dynamics

Snapshot

The Snapshot feature allows you to take a screenshot of any page. The information can be saved onto a USB device.

To take a snapshot, make sure a USB device is plugged into the vehicle. Next, press the Snapshot icon located in the lower left corner of the touchscreen.

The file will be saved to the USB drive. At the time a snapshot is taken, the bottom bar of the touchscreen will be replaced with the historical data from the vehicle present at the time the snapshot icon was pressed. The following information will display:

- Date
- Vehicle Identification Number (VIN)
- Longitude And Latitude Coordinates
- Outside Temperature
- Odometer

The following describes each feature and its operation:

TIMERS

When the Timers page is selected, you will be able to view the Drag and Accel & Braking timers.

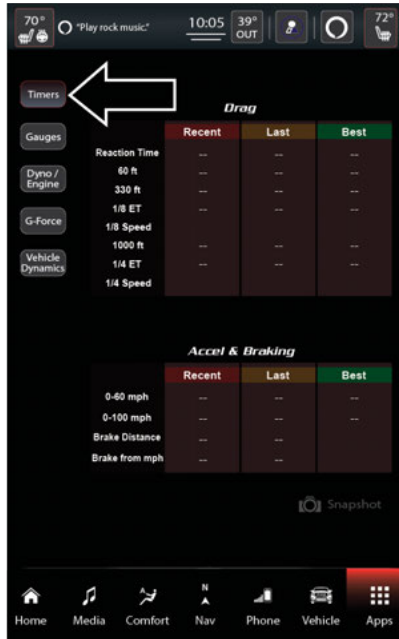

Performance Pages – Timers

- Recent

A real-time summary of performance timers for the most recent valid run, or the status of a test in progress.

- Last

The last recorded run of performance timers.

- Best

The best recorded run of performance timers, except for braking data.

Save

Pressing the SAVE button will let you save the timer data for Recent, Last, and Best recorded times to an inserted USB flash drive.

The Timers pages contain the following timers:

- **Reaction Time:** Measures the driver's reaction time for launching the vehicle against a simulated drag strip timing light (behavior modeled after 500 Sportsman Tree) displayed in the instrument cluster display.

NOTE:

Drag timers (RT, 60 ft [20 m], 330 ft [100 m], 1/8 mile [200 m], 1000 ft [300 m], and 1/4 mile [400 m]) and Acceleration Timers (0-60 mph [0-96 km/h] and 0-100 mph [0-160 km/h]) will be ready to acquire new recent data measurements when the vehicle is at 0 mph (0 km/h) and vehicle is in drive.

The following timers show the measured time required to travel when the cited distance is met. Some timers will also display speeds present at the time the distance was met.

- 0-60 mph (0-100 km/h)
- 0-100 mph (0-160 km/h)
- 60 ft (20 m) ET
- 330 ft (100 m) ET
- 1/8 Mile (200 m) + ET
- 1/8 Mile (200) + mph
- 1000 ft (300 m) ET
- 1/4 Mile (400 m) + ET
- 1/4 Mile (400 m) + mph
- Brake Distance ft (m)

NOTE:

The distance measurement will be aborted if the brake pedal is released or the parking brake is engaged, before the vehicle comes to a complete stop.

- Brake from mph (km/h)

NOTE:

Brake Distance and Speed timers only display "ready" when the vehicle is traveling at a speed greater than 30 mph (48 km/h).

GAUGES



Performance Pages – Gauges

When selected, this screen displays the following values:

- Coolant Temperature
Shows the actual coolant temperature.
- Oil Temperature
Shows the actual oil temperature.
- Oil Pressure
Shows the actual oil pressure.
- Trans Temp
Shows actual transmission oil temperature.
- Battery Voltage
Shows actual battery voltage.
- Boost Pressure – If Equipped
Shows actual boost pressure.
- Air Fuel Ratio – If Equipped
Shows current air fuel ratio.
- I/C Coolant Temp – If Equipped
Shows actual I/C Coolant temperature.
- Intake Air Temp
Shows actual intake air temperature.

If a gauge is selected, the Gauge Detail View Page will appear on the screen. This page shows gauge values for the previous two minutes on the selected gauge.

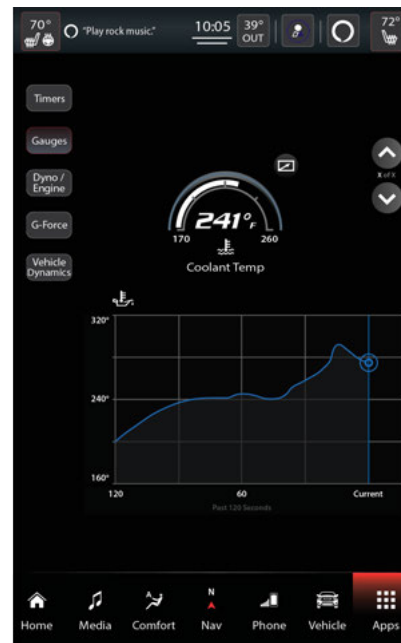

Gauge Detail View Page

Pressing the Up or Down Arrow will cycle through the details for each of the gauges. Pressing the minimize button beside the graph will return to the Gauge menu.

DYNAMOMETER (DYNO)/ENGINE

Dynamometer (Dyno)

The system will start drawing graphs for Power and Torque (top chart) and Engine Speed (bottom chart). The graph will fill from the left side of the x-axis and fill to the right side of the x-axis (based on History time selected). Once the right side of the page is reached, the graph will scroll with the right side always being the most recent recorded sample.



Performance Pages – Dyno/Engine

The following options can be selected:

- Pressing the STOP button will freeze the graph. Selecting "Play" will clear the graph and restart the process.
- Press the + or - button to change the history of the graph. The selectable options are "30", "60", "90", and "120" seconds. The graph will expand or constrict depending on the setting selected.
- Select the Gear display setting to turn the graph gear markers on or off.

NOTE:

The Gear On/Off feature will only display if your vehicle is equipped with an Automatic Transmission.

Engine

Press the Left and Right Arrow buttons on the bottom of the touchscreen to cycle between the Dyno and Engine pages.

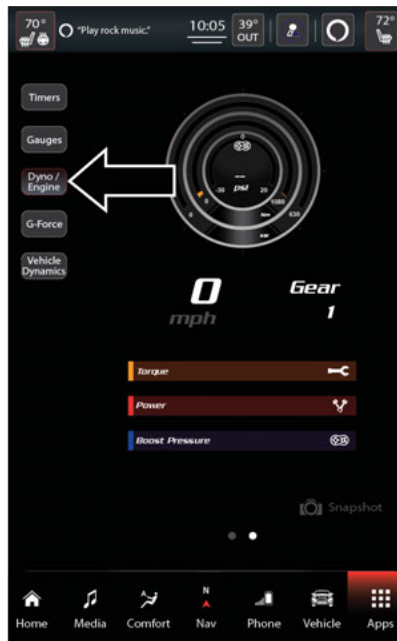

Performance Pages – Engine

When selected, this screen displays the following values:

- **Vehicle Speed:** Shows the actual vehicle speed.
- **Engine Power:** Shows the instantaneous power.
- **Engine Torque:** Shows the instantaneous torque.
- **Boost Pressure:** Shows the actual engine boost pressure.
- **Gear:** Shows the current (or pending) operating gear of the vehicle.

G-FORCE

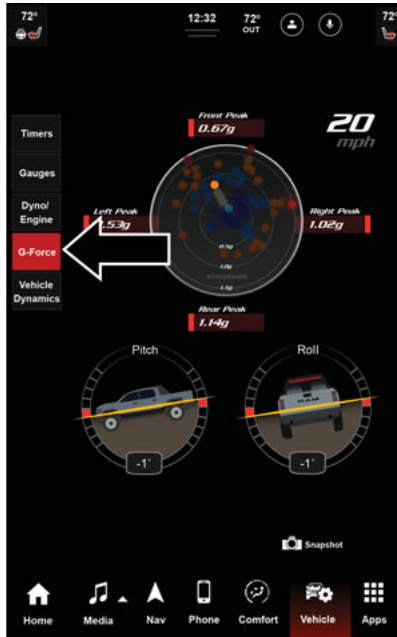

Performance Pages – G-Force

When G-Force is selected, the following features will be available:

- **Vehicle Speed**
Measures the current speed of the vehicle in either mph or km/h, starting at zero with no maximum value.
- **Front G-Force**
Measures the peak braking force on the front of the vehicle.
- **Right G-Force**
Measures the peak force on the right side of the vehicle.
- **Left G-Force**
Measures the peak force on the left side of the vehicle.
- **Rear G-Force**
Measures the peak acceleration force on the rear of the vehicle.

NOTE:

Front, Right, Left, and Rear G-Forces are all peak values. These readings can be reset by clearing peak G-Force on the instrument cluster.

The friction circle display shows instantaneous G-Force as a highlight and previous G-Force as dots within the circle. The system records previous G-Force for three minutes. If there are multiple samples at a given point, the color of the dot will darken from blue to red. Vectors more frequent will show in red; infrequent vectors will show in blue.

Pitch & Roll

The G-Force page displays the vehicle's current pitch (angle up and down) and roll (angle side to side) in degrees. The Pitch & Roll gauges provide a visualization of the current vehicle angle.

VEHICLE DYNAMICS

The Vehicle Dynamics page displays information concerning the vehicle's drivetrain.

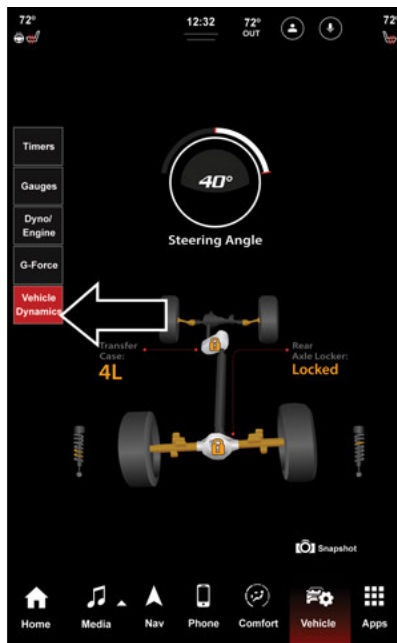

Performance Pages – Vehicle Dynamics

Steering Angle

Steering Angle utilizes the steering angle sensor to calculate the degree of the steering relative to zero (straight ahead) reference angle. The zero-degree reference angle measurement indicates the actual front tire steering angle.

Transfer Case

This feature will be active when the vehicle is in 4WD HIGH, 4WD AUTO, Neutral, or 4WD LOW.

NOTE:

A lock symbol will only be present on the Transfer Case button when the vehicle is in 4WD LOW.

Rear Axle Locker

This feature will allow you to lock and unlock the rear axle. To change the status, push the AXLE LOCK button, which is below the TRX button, on the instrument panel.

DRIVE MODES

Your vehicle is equipped with On-Road and Off-Road Drive Modes features which allow for coordinating the operation of various vehicle systems depending upon the type of driving behavior desired. The Drive Modes feature is controlled through the touchscreen and may be accessed by performing any of the following:

- Pressing the Drive Modes button within the SRT tab within the Vehicle menu on the touchscreen.
- Pushing the TRX switch on the instrument panel will bring up the TRX vehicle features list on the head unit, where the Drive Mode interface can be selected. Double pushing the TRX button will engage the Custom Drive Mode and launch the Custom Drive Modes page.
- Pushing the Left or Right Arrow button under the TRX button on the instrument panel.

NOTE:

Pressing the Left or Right Arrow button will let you switch between the different modes. Switching between the different modes will also reflect in the instrument cluster display. If the Drive Mode's interface is already open on the touchscreen, and the << or >> button is pressed, the Drive Mode's mode that was selected on the instrument cluster will appear on the touchscreen. For more information on the instrument cluster display and its interaction with Drive Modes ↪ page 17.



TRX Button

The Drive Modes main screen displays the current drive mode and real-time status of the vehicle's performance configuration. The selectable Drive Modes are "Sport", "Tow", "Snow", "Auto", "Custom", "Mud/Sand", "Rock", and "Baja". Information shown will indicate the actual status of each system, along with a vehicle graphic that displays the active drive mode status. The color red indicates "Sport," yellow for "Street", light blue for "Snow", purple for "Tow", and orange for "Baja". These features will reset to its AUTO Drive Mode configuration upon an ignition cycle if the transfer case is in 4WD AUTO or 4WD HIGH. In 4WD LOW, after an ignition cycle, the Drive Mode will return to the mode that was active when the vehicle was last turned off. If the system status shown does not match the current Drive Mode Set-Up, a message will be displayed indicating which values are not matching the current mode.

NOTE:

- Sport and Tow Modes Set-Up menus cannot be changed.
- Some parameters within Snow, Auto, Mud/Sand, Rock, and Baja Modes Set-Up menus can be configured.
- All subsystems within the Custom Mode Set-Up screen (with the exception of Rock Stability) can be configured.

ON-ROAD**On-Road Drive Modes**

- 1 – Sport
 - 2 – Tow
 - 3 – Snow
 - 4 – Auto
-

Sport Mode

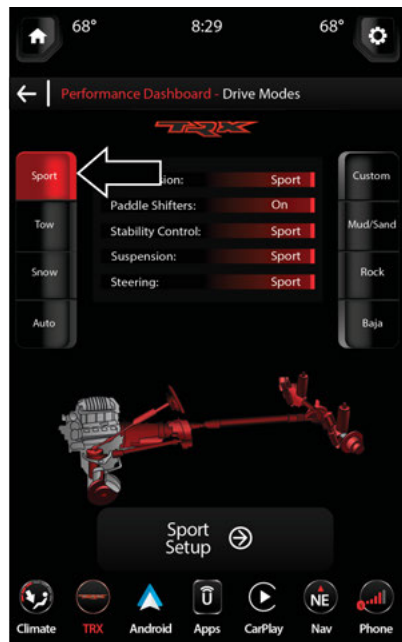

Drive Modes (Sport)

Selecting “Sport” on the touchscreen will activate the configuration for typical enthusiast driving. The Transmission, Stability Control, Steering, and Suspension systems are all set to their Sport settings highlighted in red. The paddle shifters are enabled.

NOTE:

Sport Mode is not available if the transfer case is in 4WD LOW.

Tow Mode

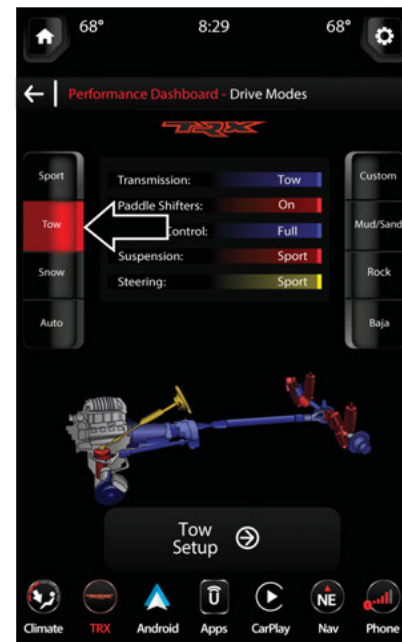

Drive Modes (Tow)

Selecting “Tow” on the touchscreen will activate the configuration for towing a trailer or hauling heavy loads in the cargo area. Once in this mode, trailer sway control is enabled in the Electronic Stability Control (ESC) system. The Transmission is set to Tow, Stability Control is set to Full, Steering is set to Street, and Suspension is set to Sport. Paddle shifters are enabled.

Snow Mode

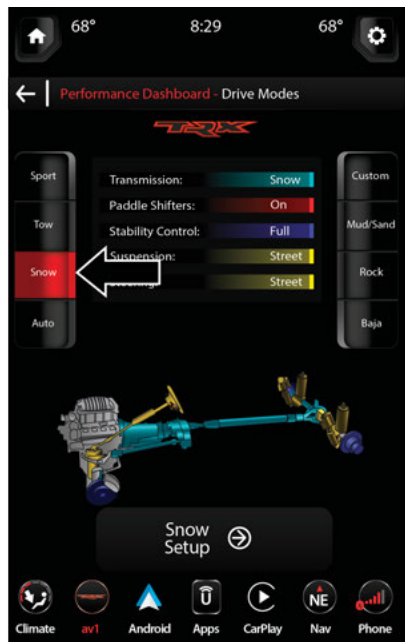

Drive Mode (Snow)

Selecting “Snow” on the touchscreen will activate Snow Mode for use on loose traction surfaces. When in Snow Mode (depending on certain operating conditions), the transmission will shift earlier than in other modes, which will keep wheel torque low to minimize wheel slippage. The Transmission is set to Snow, Stability Control is set to Full, and Steering and Suspension are set to Street. Paddle shifters are defaulted to “On” but are configurable.

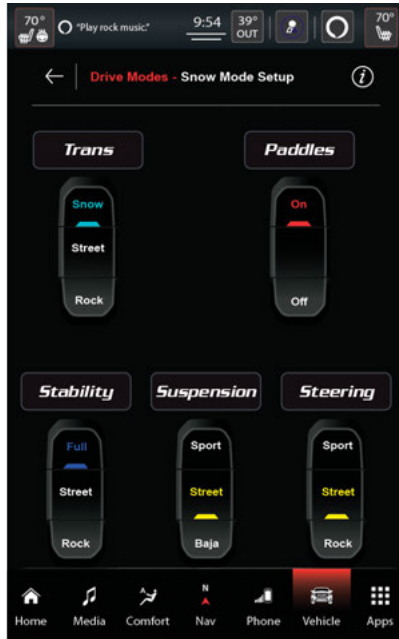

Snow Mode Set-Up

Auto Mode

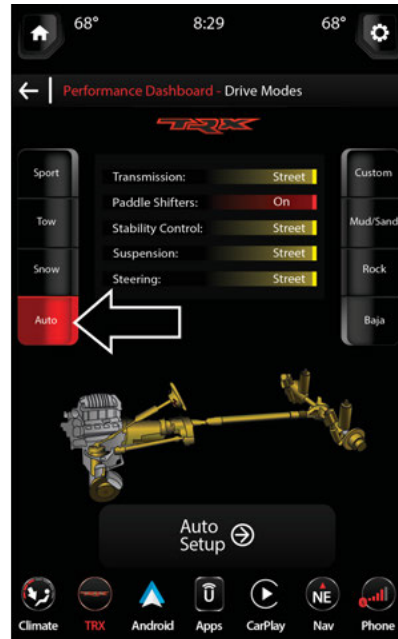

Drive Mode Auto (Default)

Auto Mode is enabled upon ignition ON while in 4WD AUTO or 4WD HIGH or by selecting "Auto" on the touchscreen. The Transmission, Stability Control, Suspension, and Steering are all set to Street. Paddle shifters are enabled.

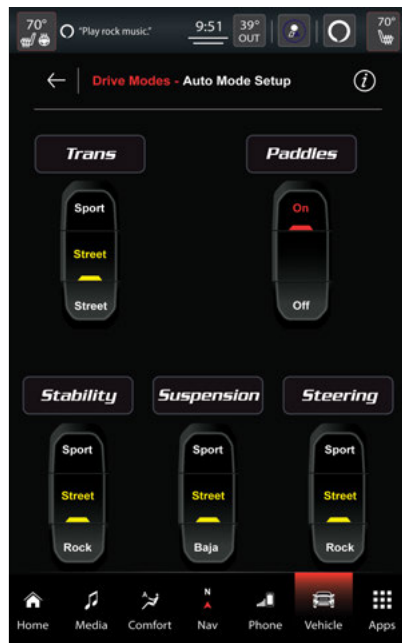

Auto Mode Set-Up

OFF-ROAD

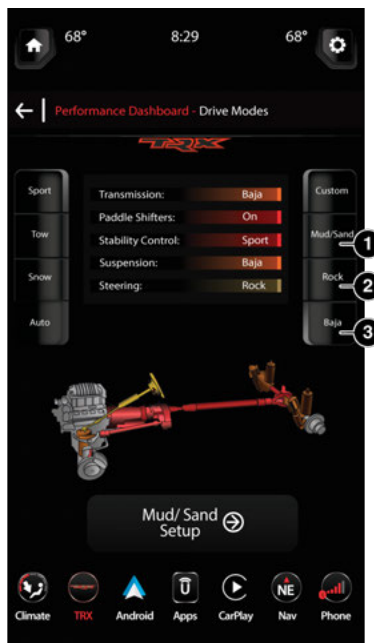

Off-Road Drive Modes

- 1 – Mud/Sand
- 2 – Rock
- 3 – Baja

Mud/Sand

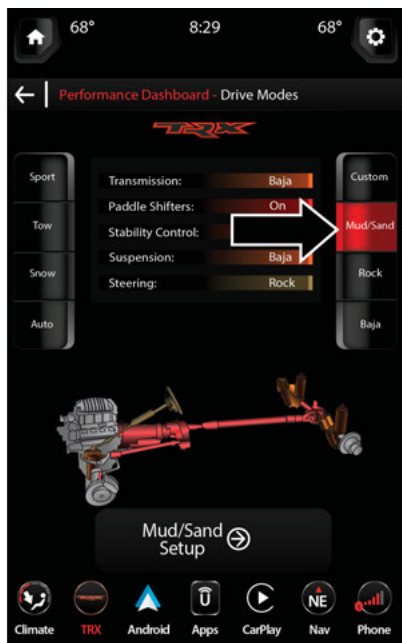

Mud/Sand Mode

Selecting “Mud/Sand” on the touchscreen will activate Mud/Sand Mode for use on mud and sand-like conditions. Transmission is set to Sport, Stability is set to Sport, Suspension is set to Baja, and Steering is set to Rock. Paddle shifters are enabled.

Rock

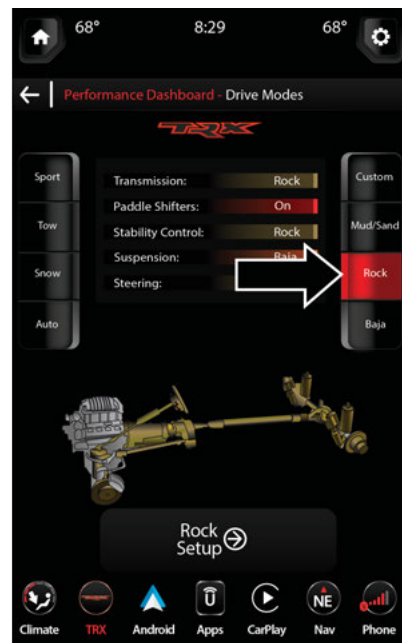

Rock Mode

Selecting “Rock” on the touchscreen will activate Rock Mode for use on rocky surfaces. Transmission and Stability are set to Sport. Steering is set to Rock. Suspension is set to Baja. Paddle shifters are enabled.

NOTE:

The vehicle must be in 4WD LOW to access Rock Mode.

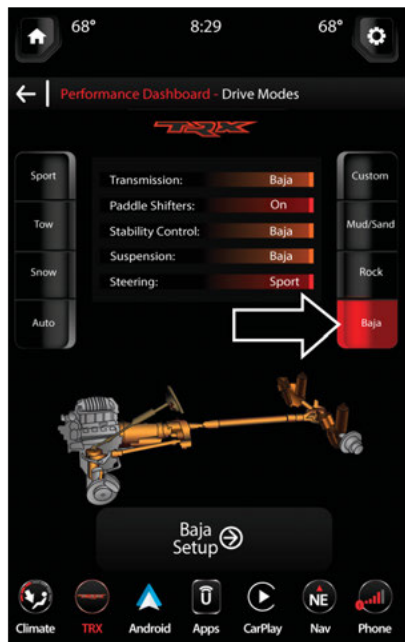
Baja**Baja Mode**

Selecting “Baja” on the touchscreen will activate Baja Mode for high-speed off-road driving. Transmission, Suspension, and Stability are set to Baja. Steering is set to Sport. Paddle shifters are enabled.

NOTE:

Baja Mode is not available in 4WD LOW.

CUSTOM MODE

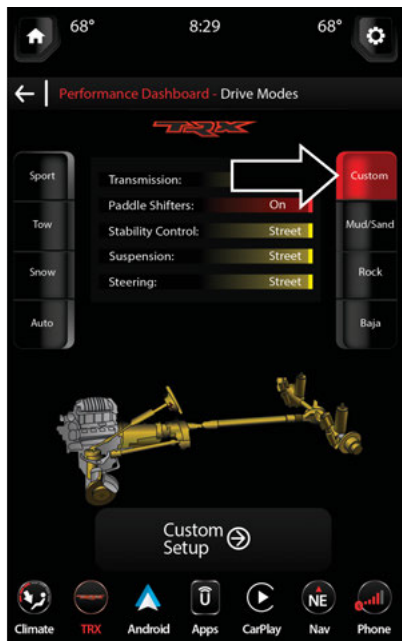

Custom Mode

Custom Mode may be selected by pressing the Custom button on the touchscreen or by pushing the TRX button twice within two seconds. Custom Mode allows you to create a custom configuration that is saved for quick selection of your favorite settings. While in Custom Mode, the Transmission, Paddles, Steering, Stability, and Suspension settings are shown in their current configuration.

While on the Custom Mode screen, press the Custom Setup button on the touchscreen to access the set-up page options. Select which mode suits your driving needs for a custom driving experience.

Drive Mode Set-Up Info

Within the Drive Mode Set-Up screen, press the Info button on the touchscreen then use the Left/Right arrow towards the bottom of the touchscreen to scroll through all the available Drive Mode systems giving you a description of their operation and current configuration.

NOTE:

Not all levels are adjustable in each Drive Mode Set-Up.

Transmission



Transmission

- **Sport:** Faster shift speeds with some comfort trade-off.
- **Tow:** Optimizes shifting for towing and hauling.
- **Snow:** Optimizes shifting for low-traction conditions.
- **Street:** A balance of shift speed and comfort for typical daily driving.
- **Baja:** Performs aggressive shifting for off-road performance.
- **Rock:** Optimized shifting for traversing rocky terrain.

Paddle Shifters

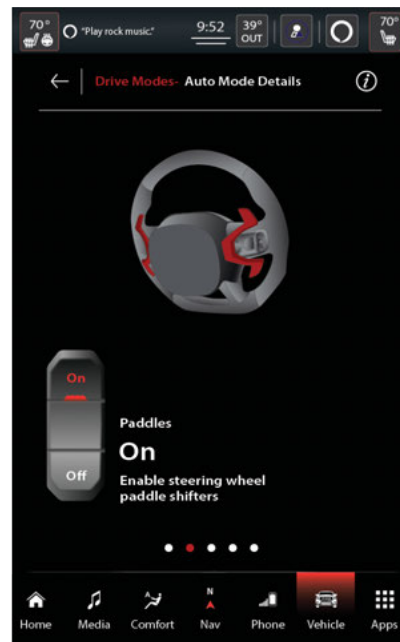

Paddle Shifters

- **On:** Enables steering wheel paddle shifters.
- **Off:** Disables steering wheel paddle shifters.

Stability Control



Stability Control

- **Sport:** Provides reduced stability control.
- **Street:** Provides full (default) stability control.
- **Full:** Provides traction control and stability control optimized for slippery conditions.
- **Baja:** Optimizes the Anti-Brake System (ABS), traction control, and stability control for high-speed off-road driving.
- **Rock:** Optimizes traction control for low-speed off-road driving/crawling.

Suspension



Suspension

- **Sport:** Provides a firmer suspension stiffness with moderate comfort trade-off.
- **Street:** Provides a balance of suspension stiffness and ride comfort for typical daily driving.
- **Baja:** Optimizes for high-speed off-road driving.

Steering

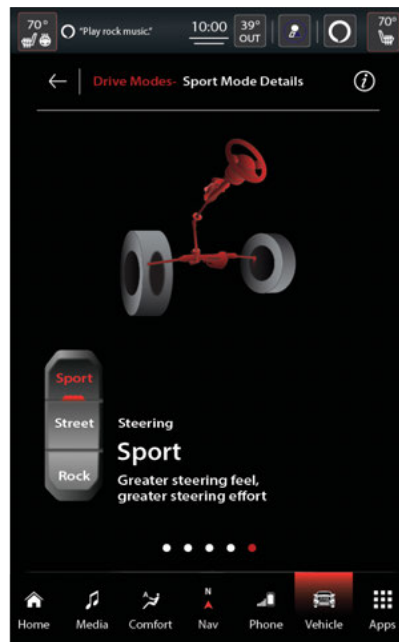

Steering

- **Sport:** Adjusts the steering effort and feel to a greater level.
- **Street:** Balances the steering feel and comfort.
- **Rock:** Provides the greatest steering feel and effort for improved control.

RACE OPTIONS

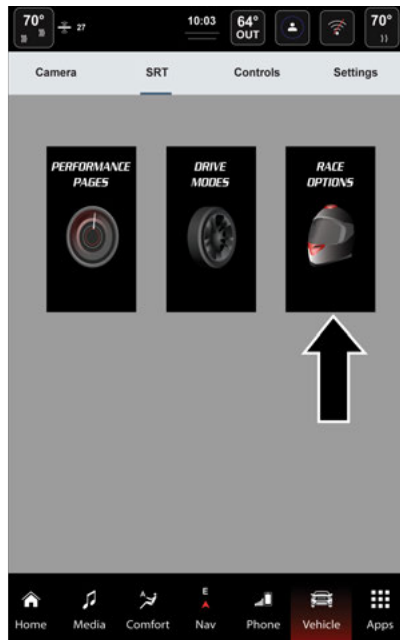

Race Options

Press the Race Options tab on the touchscreen to display the vehicle's Launch Control screen. Within Race Options, you can activate, deactivate, and adjust the RPM values for the Launch Control, Race Cooldown, and Shift Light features
 ☞ page 61.

Launch Control

WARNING!

Launch Control is intended for off-highway or off-road use only and should not be used on any public roadways. It is recommended that this feature be used in a controlled environment, and within the limits of the law. The capabilities of the vehicle as measured by the performance pages must never be exploited in a reckless or dangerous manner, which can jeopardize the user's safety or the safety of others. Only a safe, attentive, and skillful driver can prevent accidents.

This vehicle is equipped with a Launch Control system that is designed to allow the driver to achieve maximum vehicle acceleration in a straight line. Launch Control is a form of traction control that manages tire slip while launching the vehicle. This feature is intended for use during race events on a closed course where consistent 1/4-mile and 0-to-60 times are desired. The system is not intended to compensate for lack of driver experience or familiarity with the race track. Use of this feature in low traction (cold, wet, gravel, etc.) conditions may result in excess wheel slip outside this systems control resulting in an aborted launch.

Preconditions:

- Launch Control should not be used on public roads. Always check track conditions and the surrounding area.
- Launch Control is not available within the first 500 miles (805 km) of engine break-in.
- Launch Control should only be used when the engine and transmission are at operating temperature.
- Launch Control is intended to be used on dry, paved road surfaces only.
- Launch Control will not be available when in 4WD LOW or while operating in Valet Mode.

Launch Control is only available when the following procedure is followed:

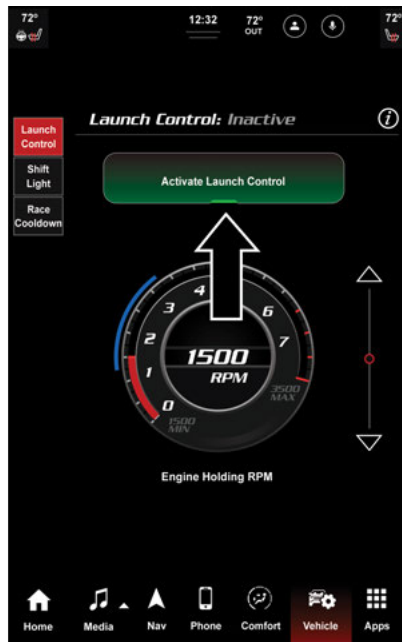

Activate Launch Control

1. Adjust your launch RPMs for optimum launch/traction, if required.
2. Press the Activate Launch Control button on the touchscreen or press the Launch button on the instrument panel; follow instructions on the instrument cluster display.
 - Make sure the vehicle is not moving.
 - Put vehicle in first gear or Drive.
 - Steering wheel must be centered with tires pointing forward.
 - Vehicle must be on level ground.
 - Apply brake pressure.
 - While holding the brake, rapidly apply and hold the accelerator pedal to wide open throttle. The engine speed will hold at the RPM that was set in the “Launch Control” screen.

NOTE:

Messages will appear in the instrument cluster display to inform the driver if one or more of the above conditions have not been met.

3. When the above conditions have been met, the instrument cluster display will read “Release Brake”.
4. Keep the vehicle pointed straight and release the brake.

Launch Control will be active until the vehicle reaches 62 mph (100 km/h), at which point the Electronic Stability Control (ESC) system will return to its current ESC mode.

Launch Control will abort before launch completion and will display “Launch Aborted” in the cluster under any the following conditions:

- The accelerator pedal is released during launch.
- The ESC system detects that the vehicle is no longer moving in a straight line.
- The ESC Off button is pressed to change the system to another mode.

NOTE:

The Launch Control RPM setting can only be adjusted while Launch Control is not active. After Launch Control has been aborted, ESC will return to its current ESC mode.

CAUTION!

Do not attempt to shift when the drive wheels are spinning and do not have traction. Damage to the transmission may occur.

To adjust the Launch RPM, drag the slider bar or press the arrows on the touchscreen to adjust the holding RPM. The launch RPM limit is between the minimum and maximum RPM values shown on the gauge, in 100 RPM increments.

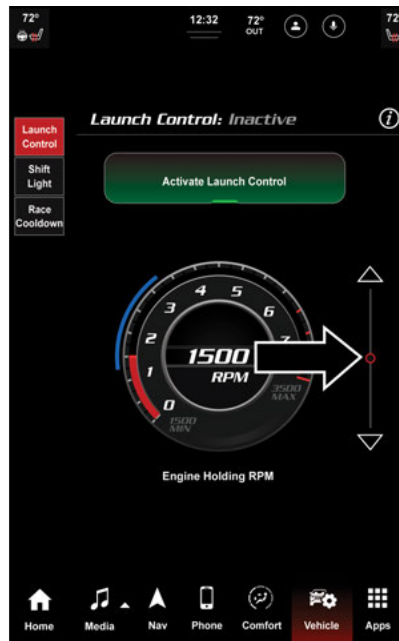

Launch RPM Set-Up

Shift Light

Your vehicle is equipped with a Shift Light feature that illuminates the instrument cluster display as a visual cue to manually upshift using the paddle shifters or shifting the transmission gear selector.



Shift Light Button

To actuate the Shift Light feature, press the Race Options tab, then press the Deactivate Shift Light button on the touchscreen. Activation is shown on the instrument cluster display.

Shift Light is only active when the gear selector is in Autostick or Sport position.

NOTE:

Paddle shifters can be used to shift, however using the paddle shifters while the shifter is in Drive (D) position will not enable the Shift Light feature.

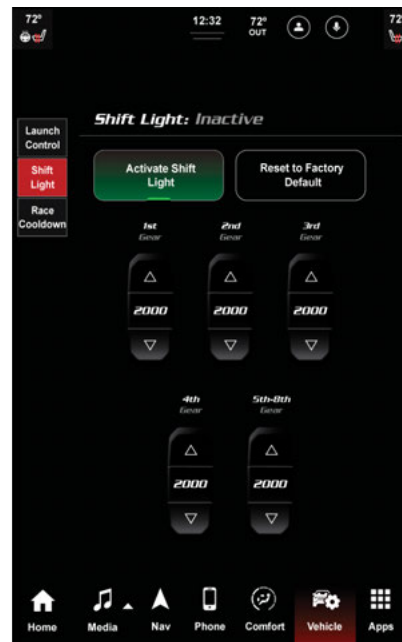

Shift Light RPM Set-Up

The Shift Light RPM Set-Up allows you to set the Shift Light to illuminate for gears 1, 2, 3, 4, and 5-8. Pressing and releasing the Up/Down arrow buttons above and below each listed gear, the RPM values will change in increments of 250 RPM. Pressing and holding the arrows will change the RPM values in increments of 500 RPM, up to 6250 RPM. Press the Reset to Factory Default button on the touchscreen to change back to factory settings, or press the Deactivate Shift Light button on the touchscreen to turn the system off completely.

Race Cooldown – If Equipped

Race Cooldown is a selectable After-Run Cooling feature.

Race Cooldown is a feature activated by selecting the Race Cooldown button under the Race Options tab.

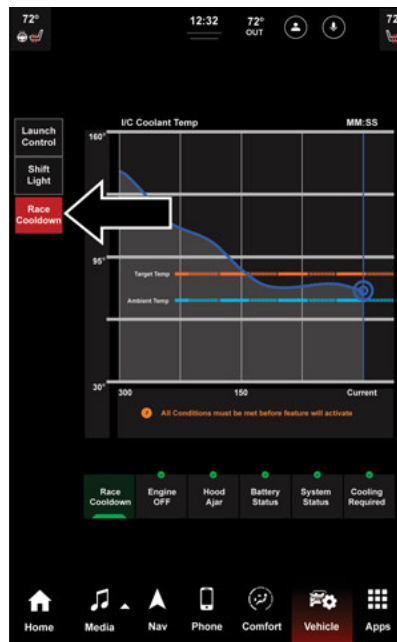

Race Cooldown Button

To enable this feature, the vehicle will check to ensure the engine is off, the hood is closed, the status of the battery and system are acceptable and determine if cooling is required.

After completing an event that has generated a lot of heat in the powertrain, this feature helps cool the vehicle after the engine has been shut down. The radiator fan and low temperature radiator coolant pump remain on after engine shutdown for a period up to five minutes or until target temperature is reached.

A graph in the radio can show the resulting intercooler coolant temperature in real time while the vehicle ignition is in ON/RUN position with the engine off.

NOTE:

Race Cooldown feature (After-Run) will only come on with the engine off. The temperature will display with engine running also, but After-Run Cooling will not be functioning.

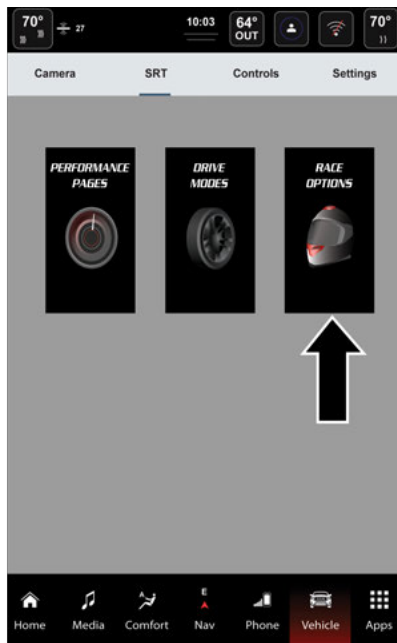

Race Options

This feature will automatically deactivate after extended driving at road speeds, or when one or more of the following conditions apply:

- If coolant temperature reaches the target temperature and cooling is no longer required.
- If battery voltage or state of charge drops below a threshold.
- If the hood is opened.

GUIDELINES FOR TRACK OR EXTREME OFF-ROAD USE

- If your vehicle is equipped with Drive Modes, they will alter the vehicle's performance in various driving situations. It is recommended that your vehicle operates in Sport or Baja Mode during the event.
- Prior to each event, verify all fluids are at the correct levels.

- Prior to each event, verify the front and rear brake pads have more than half pad thickness remaining. If the brake pads require changing, complete a brake burnish procedure prior to an event at full pace.
- At the conclusion of each event, it is recommended that a brake bleed procedure is performed to maintain the pedal feel and stopping capability of your brake system.
- It is recommended that each event outing should end with a minimum of one cooldown lap using minimal braking.
- All vehicles are severe use tested for 24 hours of endurance. However, it is recommended that the suspension system, brake system, prop shaft, and half shaft boots be checked for wear or damage after every event.
- Aggressive usage results in increased operating temperatures of the engine, transmission, driveline, and brake system. This may affect Noise Vibration Harshness (NVH) countermeasures of your vehicle. New components may need to be installed to return the system to the original NVH performance.
- Tire pressure:
 - Recommended tire pressure of 25 psi (172 kPa) when tires are cold, or below 38 psi (262 kPa) when hot.

NOTE:

It is recommended that you target below 38 psi (262 kPa) when tires are hot at the conclusion of each session. Starting at 25 psi (172 kPa) cold and adjusting based on ambient and conditions is recommended. Tire pressure can be monitored via the instrument cluster display and can assist with adjustments.

VALET MODE

To enter Valet Mode, press the Valet Mode button from the All Profiles menu on the touchscreen. For more information on Profiles, please refer to your Uconnect Owner's Manual Supplement.

While in Valet Mode, the following vehicle configurations are set and locked to prevent unauthorized modification:

- Transmission upshifts earlier than normal.
- Steering and Suspension are set to their Street settings.
- Steering wheel paddle shifters are disabled.
- The ESC Off button is disabled.
- The Launch Control button is disabled.
- Engine power is reduced.

When the vehicle is started or was previously placed in Valet Mode, a pop-up will display that the vehicle is in Valet Mode. Select "Yes" to deactivate valet mode. Alternatively, press the Locked Profile icon in the Upper Status Bar to exit Valet Mode.

Enter your four-digit Valet Mode PIN and press "Go". Valet Mode will be deactivated. The Uconnect system will load the last active Profile before the vehicle was placed in Valet Mode.

NOTE:

If your four-digit PIN is lost or forgotten, the vehicle will exit Valet Mode after a battery disconnect for approximately five minutes. Reconnect the battery and cycle the ignition to the ON/RUN position. The vehicle will be in Auto Mode.

SAFETY

SAFETY FEATURES

ELECTRONIC STABILITY CONTROL (ESC)

ESC enhances directional control and stability of the vehicle under various driving conditions. ESC corrects for oversteering or understeering of the vehicle by applying the brake of the appropriate wheel(s) to counteract the above conditions. Engine power may also be reduced to help the vehicle maintain the desired path.

- Oversteer — when the vehicle is turning more than appropriate for the steering wheel position.
- Understeer — when the vehicle is turning less than appropriate for the steering wheel position.

ESC uses sensors in the vehicle to determine the vehicle path intended by the driver and compares it to the actual path of the vehicle. When the actual path does not match the intended path, ESC applies the brake of the appropriate wheel to assist in counteracting the oversteer or understeer condition.

The ESC Activation/Malfunction Indicator Light located in the instrument cluster will start to flash as soon as the ESC system becomes active. The ESC Activation/Malfunction Indicator Light also flashes when the TCS is active. If the ESC Activation/Malfunction Indicator Light begins to flash during acceleration, ease up on the accelerator and apply as little throttle as possible. Be sure to adapt your speed and driving to the prevailing road conditions.

WARNING!

- Electronic Stability Control (ESC) cannot prevent the natural laws of physics from acting on the vehicle, nor can it increase the traction afforded by prevailing road conditions. ESC cannot prevent accidents, including those resulting from excessive speed in turns, driving on very slippery surfaces, or hydroplaning. ESC also cannot prevent accidents resulting from loss of vehicle control due to inappropriate driver input for the conditions. Only a safe, attentive, and skillful driver can prevent accidents. The capabilities of an ESC equipped vehicle must never be exploited in a reckless or dangerous manner which could jeopardize the user's safety or the safety of others.

(Continued)

WARNING!

- Vehicle modifications, or failure to properly maintain your vehicle, may change the handling characteristics of your vehicle, and may negatively affect the performance of the ESC system. Changes to the steering system, suspension, braking system, tire type and size or wheel size may adversely affect ESC performance. Improperly inflated and unevenly worn tires may also degrade ESC performance. Any vehicle modification or poor vehicle maintenance that reduces the effectiveness of the ESC system can increase the risk of loss of vehicle control, vehicle rollover, personal injury and death.

ESC OPERATING MODES

The following ESC operating modes are available:

- **Sport:** Provides reduced stability control.
- **Auto:** Provides full (default) stability control.
- **Snow:** Provides traction control and stability control optimized for slippery conditions.
- **Baja:** Optimizes the Anti-Lock Brake System (ABS), traction control, and stability control for high-speed off-road driving.
- **Sand Mud:** Optimizes traction control for low-speed off-road driving/crawling.

NOTE:

Not all ESC operating modes are selectable in the setup menu. Some ESC settings are preconfigured by the selected drive mode and may not be adjusted; see ⇨ page 47 for additional information.

WARNING!

- When in “Partial Off” mode, the TCS functionality of ESC (except for the limited slip feature described in the TCS section) has been disabled and the ESC OFF Indicator Light will be illuminated. When in “Partial Off” mode, the engine power reduction feature of TCS is disabled, and the enhanced vehicle stability offered by the ESC system is reduced.
- Trailer Sway Control (TSC) is disabled when the ESC system is in the “Partial Off” mode.

WARNING!

- In the ESC “Full Off” mode, the engine torque reduction and stability features are disabled. Therefore, enhanced vehicle stability offered by the ESC system is unavailable. In an emergency evasive maneuver, the ESC system will not engage to assist in maintaining stability. ESC “Full Off” mode is intended for off-highway or off-road use only.
- The Electronic Stability Control (ESC) cannot prevent the natural laws of physics from acting on the vehicle, nor can it increase the traction afforded by prevailing road conditions. ESC cannot prevent all accidents, including those resulting from excessive speed in turns, driving on very slippery surfaces, or hydroplaning. ESC also cannot prevent collisions.

SAFETY TIPS**FLUID LEAKS**

Check area under the vehicle after overnight parking for fuel, coolant, oil, or other fluid leaks. Also, if gasoline fumes are detected or if fuel or brake fluid leaks are suspected, the cause should be located and corrected immediately.

WARNING!

To prevent **SERIOUS INJURY** or **DEATH** when using “Track-Use” parts and equipment:

- **NEVER** use any “Track-Use” equipment on public roads. FCA US LLC does not authorize the use of “Track-Use” equipment on public roads.
- The intended use of “Track-Use” parts is for race vehicles on race tracks. To help ensure the safety of the race driver, engineers should supervise the installation of “Track-Use” parts.
- FCA US LLC does not authorize the installation or use of any part noted as “Track-Use” on any new vehicle prior to its first retail sale.

WARNING!

To prevent **SERIOUS INJURY** or **DEATH**:

- **ALWAYS** remove any “Track-Use” equipment before driving on public roads.
- **ALWAYS** properly use your three-point seat belts when driving on public roads.
- In a collision, you and your passengers can suffer much greater injuries if you are not properly buckled up. You can strike the interior of your vehicle or other passengers, or you can be thrown out of the vehicle.

IN CASE OF EMERGENCY

JACKING AND TIRE CHANGING

WARNING!

- Do not attempt to change a tire on the side of the vehicle close to moving traffic. Pull far enough off the road to avoid the danger of being hit when operating the jack or changing the wheel.
- Being under a jacked-up vehicle is dangerous. The vehicle could slip off the jack and fall on you. You could be crushed. Never put any part of your body under a vehicle that is on a jack. If you need to get under a raised vehicle, take it to a service center where it can be raised on a lift.
- Never start or run the engine while the vehicle is on a jack.
- The jack is designed to be used as a tool for changing tires only. The jack should not be used to lift the vehicle for service purposes. The vehicle should be jacked on a firm level surface only. Avoid ice or slippery areas.

PREPARATIONS FOR JACKING

1. Park on a firm, level surface. Avoid ice or slippery areas.

WARNING!

Do not attempt to change a tire on the side of the vehicle close to moving traffic. Pull far enough off the road to avoid being hit when operating the jack or changing the wheel.

2. Turn on the Hazard Warning Flashers.
3. Apply the parking brake.
4. Shift the transmission into PARK (P).
5. Turn the ignition OFF.
6. Block both the front and rear wheel diagonally opposite of each jacking position. For example, if the driver's front wheel is being changed, block the passenger's rear wheel.

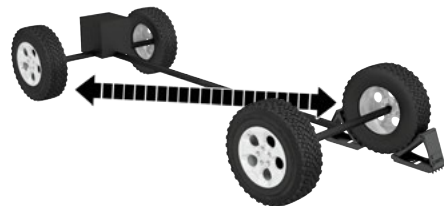

B0707001153US

Wheel Blocked

NOTE:

Passengers should not remain in the vehicle when the vehicle is being raised or lifted.

JACK LOCATION

The jack and tools are stored under the front passenger seat.

REMOVAL OF JACK AND TOOLS

To access the jack and tools, you must remove the plastic access cover located on the side of the front passenger's seat. To remove the cover, pull the front part of the cover (closest to the front of the seat) toward you to release a locking tab. Once the front of the cover is loose, slide the cover toward the front of the seat until it is free from the seat frame.



Pull Jack Access Cover From Front

Remove the jack and tools by turning the wing bolt counterclockwise, remove the wing bolt and then slide the assembly out from under the seat.



Jack And Tools

Release the tool bag straps from the jack and remove tools from bag.



Jack And Tool Bag

There are two ways to assemble the tools:

Assembled For Spare Tire Lowering/Raising

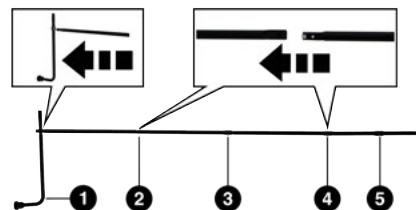

A0707000783US

Assembled For Spare Tire Lowering/Raising

- 1 – Lug Wrench
- 2 – Long Extension Without Spring Clip
- 3 – Long Extension With Spring Clip
- 4 – Long Extension With Spring Clip
- 5 – Short Extension

NOTE:

If the tailgate is lowered, adding the shorter extension 5 to jack extension 4 will enable lowering the spare tire without having to raise the tailgate.

CAUTION!

- The lug wrench can only be attached to extension 2.
- When attaching the tool to the winch mechanism be sure the large flared end opening on extension 4 is positioned correctly over the winch mechanism adjusting nut.
- Damage to the lug wrench, extensions and winch mechanism may occur from improper tool assembly.

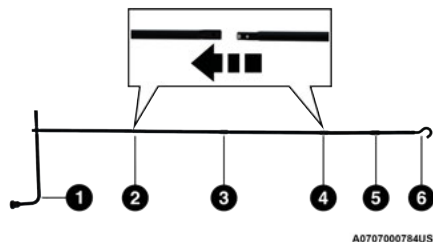
Assembled For Jack Operation**Assembled For Jack Operation**

- 1 – Lug Wrench
- 2 – Long Extension 2
- 3 – Long Extension 3
- 4 – Long Extension 4
- 5 – Short Extension 5
- 6 – Extension With Hook

WARNING!

After using the jack and tools, always reinstall them in the original carrier and location. While driving you may experience abrupt stopping, rapid acceleration or sharp turns. A loose jack, tools, bracket or other objects in the vehicle may move around with force, resulting in serious injury.

REMOVING THE SPARE TIRE

1. Remove the spare tire before attempting to jack up the truck. Attach the lug wrench to the extension tubes with the curved angle facing away from the vehicle.
2. Remove the protective cover over the access hole for the winch mechanism by sliding the cover upward.

**Access Hole Cover Location**

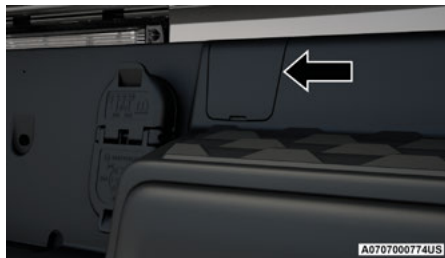
**Access Hole Cover**

3. Insert the extension tube through the access hole between the lower tailgate and the top of the fascia/bumper and into the winch mechanism tube.

**Winch Mechanism Tube****Inserting The Extension Tubes Into The Access Hole**

4. Rotate the lug wrench handle counter-clockwise until the spare tire is on the ground with enough cable slack to allow you to pull it out from under the vehicle.
5. Pull the spare tire out from under the vehicle to gain access to the spare tire retainer.

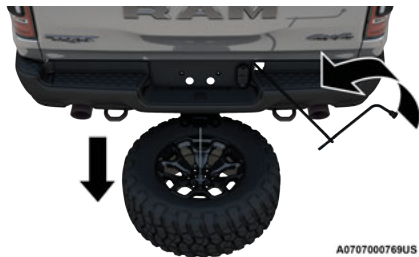
**Pulling The Spare Tire Out**

6. Lift the spare tire with one hand to give clearance to tilt the retainer at the end of the cable.
7. Pull the retainer through the center of the wheel.

**Pulling The Retainer Through The Center Of The Wheel****NOTE:**

The winch mechanism is designed for use with the extension tubes only. Use of an air wrench or other power tools is not recommended and can damage the winch.

JACKING INSTRUCTIONS

WARNING!

Carefully follow these tire changing warnings to help prevent personal injury or damage to your vehicle:

- Always park on a firm, level surface as far from the edge of the roadway as possible before raising the vehicle.
- Turn on the Hazard Warning Flashers.
- Apply the parking brake firmly and set the transmission in PARK.
- Block the wheel diagonally opposite the wheel to be raised.
- Never start or run the engine with the vehicle on a jack.
- Do not let anyone sit in the vehicle when it is on a jack.
- Do not get under the vehicle when it is on a jack. If you need to get under a raised vehicle, take it to a service center where it can be raised on a lift.

(Continued)

WARNING!

- Only use the jack in the positions indicated and for lifting this vehicle during a tire change.
- If working on or near a roadway, be extremely careful of motor traffic.
- To assure that spare tires, flat or inflated, are securely stowed, spares must be stowed with the valve stem facing the ground.



Jack Warning Label

1. Remove the spare tire, jack, and tools from the stored location.
2. Using the lug wrench, loosen the wheel nuts (do not remove), by turning them counter-clockwise one turn while the wheel is still on the ground.

3. Assemble the jack and jacking tools. Connect the jack handle driver to the extension, then to the lug wrench.

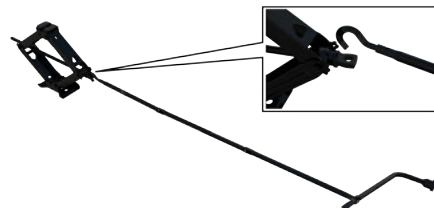

A0707000787US

Assembled Jack And Tools

4. Placement for the front and rear jacking locations are critical. See the following images for proper jacking locations.

CAUTION!

Do not attempt to raise the vehicle by jacking on locations other than those indicated in the Jacking Instructions for this vehicle.



A0707000826US

Jack Placement

When changing a front wheel, place the scissor jack under the rear portion of the lower control arm as shown. **The front jacking location is accessible from behind the front tire.**

Front Jacking Location



A0707000751US

Front Lifting Point



A0707000805US

Front Jacking Location

Rear Jacking Location

Operate the jack using the extension with jack hook and the lug wrench. The extension tubes may be used but is not required.

When changing a rear wheel, assemble the extension with jack hook to the jack and connect the extension tubes. **Access the rear jacking location from behind the rear tire.** Place the jack under the Jack Lifting Point located on the rear axle lower control arm bracket. Then locate the slot in the jack lift plate onto the rear axle Jack Lifting Point. Attach the extension with jack hook extending to the rear of the vehicle.

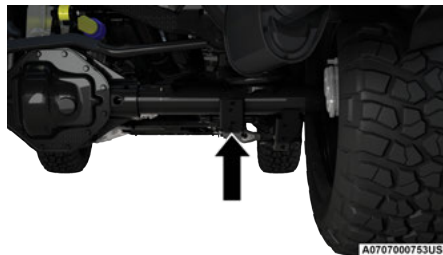

A0707000753US

Rear Lifting Point



A0707000795US

Rear Jacking Location

Connect the long extensions to the lug wrench.

CAUTION!

Before raising the wheel off the ground, make sure that the jack will not damage surrounding truck parts and adjust the jack position as required.

- By rotating the lug wrench clockwise, raise the vehicle until the wheel just clears the ground surface.

WARNING!

Raising the vehicle higher than necessary can make the vehicle less stable. It could slip off the jack and hurt someone near it. Raise the vehicle only enough to remove the tire.

- Remove the lug nuts and pull the wheel off. Install the spare wheel and lug nuts with the cone shaped end of the lug nuts toward the wheel. Hand tighten the lug nuts with the vehicle lifted. To avoid the risk of forcing the vehicle off the jack, do not fully tighten the lug nuts until the vehicle has been completely lowered.
- Finish tightening the lug nuts. Push down on the wrench handle for increased leverage. Tighten the lug nuts in a star pattern until each lug nut has been tightened twice. For the correct lug nut torque refer to "Wheel And Tire Torque Specifications" in "Technical Specifications" of the Owner's Manual. If in doubt about the correct tightness, have them checked with a torque wrench by an authorized dealer or at a service station.

WARNING!

A loose tire or jack thrown forward in a collision or hard stop, could endanger the occupants of the vehicle. Always stow the jack parts and the spare tire in the places provided.

- If your vehicle is equipped with a wheel center cap, install the cap and remove the wheel blocks. Do not install chrome or aluminum wheel center caps on the spare wheel. This may result in cap damage.
- Lower the jack to its fully closed position. Stow the replaced tire, and secure the jack and tools in the proper location.
- Adjust the tire pressure when possible.

To STOW THE FLAT OR SPARE**WARNING!**

A loose tire or jack thrown forward in a collision or hard stop could endanger the occupants of the vehicle. Always stow the jack parts and the spare tire in the places provided. Have the deflated (flat) tire repaired or replaced immediately.

- Turn the wheel so that the valve stem is facing upward and toward the rear of the vehicle for convenience in checking the spare tire inflation. Slide the wheel retainer through the center of the wheel.
- Lift the spare tire with one hand to give clearance to tilt the retainer at the end of the cable and position it properly across the wheel opening.



Positioning Retainer Through Center Of Wheel

- Remove the extension with the hook and reattach the short extension 5 ⇨ page 70. Attach the lug wrench to the extension tubes with the curved angle facing away from the vehicle. Insert the extension tubes through the access hole between the lower tailgate and the top of the fascia/bumper and into the winch mechanism tube.

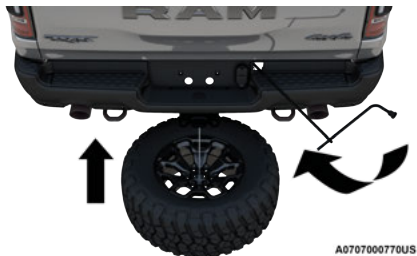

A0707000770US

Reinstalling The Flat Or Spare Tire

- Rotate the lug wrench handle clockwise until the wheel is drawn into place against the underside of the vehicle. Continue to rotate until you feel the winch mechanism slip, or click three or four times. It cannot be overtightened. Push against the tire several times to ensure it is firmly in place.

NOTE:

The winch mechanism is designed for use with the extension tube only. Use of an air wrench or other power tools is not recommended and can damage the winch.

REINSTALLING THE JACK AND TOOLS

- Tighten the jack all the way down by turning the jack turn-screw counterclockwise until the jack is snug.
- Position the jack and tool bag. Make sure the lug wrench is under the jack near the jack turn-screw.

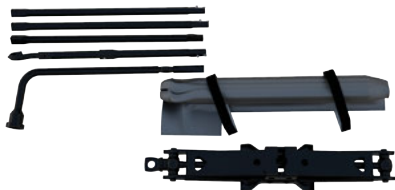

A0707000782US

Jack And Tool Bag

- Secure the tool bag straps to the jack.



A0707000785US

Jack And Tools Tied

- Place the jack and tools in the storage position holding the jack by the jack turn-screw, slip the jack and tools under the seat so that the bottom slot engages into the fastener on the floor.

NOTE:

Ensure that the jack slides into the front hold down location.

5. Turn the wing bolt clockwise to secure to the floor pan. Reinstall the plastic cover.

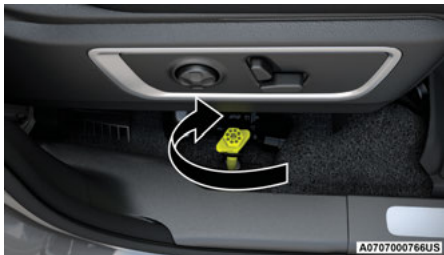

Jack Hold Down Wing Bolt

WARNING!

After using the jack and tools, always reinstall them in the original carrier and location. While driving you may experience abrupt stopping, rapid acceleration or sharp turns. A loose jack, tools, bracket or other objects in the vehicle may move around with force, resulting in serious injury.

FRONT AND REAR TOW HOOKS

For off road recovery, it is recommended to use both of the front or rear tow hooks with an appropriately rated tow strap to minimize the risk of damage to the vehicle.



Front Tow Hooks



Rear Tow Hooks

WARNING!

- Do not use a chain for freeing a stuck vehicle. Chains may break, causing serious injury or death.
- Stand clear of vehicles when pulling with tow hooks. Tow straps may become disengaged, causing serious injury.

CAUTION!

Tow hooks are for emergency use only, to rescue a vehicle stranded off road. Do not use tow hooks for tow truck hookup or highway towing. Do not use tow hooks as an anchor point for tie-down when securing on a transport vehicle. You could damage your vehicle.

SERVICING AND MAINTENANCE

SCHEDULED SERVICING

The Scheduled Maintenance services listed in this manual must be done at the times or mileages specified to protect the vehicle warranty and ensure the best vehicle performance and reliability. More frequent maintenance may be needed for vehicles in severe operating conditions, such as dusty areas and very short trip driving. Inspection and service should also be done anytime a malfunction is suspected.

The oil change indicator system will remind you that it is time to take your vehicle in for scheduled maintenance.

The instrument cluster display will display an “Oil Change Required” message and a single chime will sound, indicating that an oil change is necessary. Based on engine operation conditions, the oil change indicator message will illuminate.

This means that service is required for your vehicle. Have your vehicle serviced as soon as possible, within the next 500 miles (805 km).

NOTE:

- The oil change indicator message will not monitor the time since the last oil change. Change your vehicle's oil if it has been six months since your last oil change, even if the oil change indicator message is NOT illuminated.
- Change your engine oil more often if you drive your vehicle off-road for an extended period of time.
- Under no circumstances should oil change intervals exceed 6,000 miles (10,000 km) or six months, whichever comes first.

An authorized dealer will reset the oil change indicator message after completing the scheduled oil change. If a scheduled oil change is performed by someone other than an authorized dealer, the message can be reset by referring to the steps described under instrument cluster display. Refer to “Instrument Cluster Display” in “Getting To Know Your Instrument Panel” in the Owner’s Manual for further information.

Severe Duty All Models

Vehicles that are operated in a dusty and off-road environment, or predominately at idle or very low engine RPM are known as Severe Duty vehicles. It is recommended that you change engine oil at 4,000 miles (6,500 km) or 350 hours of engine run time.

At Each Stop For Fuel

- Check the windshield washer solvent and add if required.

Once A Month

- Check tire pressure and look for unusual wear or damage.
- Inspect the battery, and clean and tighten the terminals as required.
- Check the fluid levels of the coolant reservoir, engine oil, brake master cylinder, and add as needed.
- Check all lights and other electrical items for correct operation.

At Each Oil Change

- Change the engine oil filter.
- Inspect the brake hoses and lines.
- Inspect the CV/Universal joints.

CAUTION!

Failure to perform the required maintenance items may result in damage to the vehicle.

MAINTENANCE PLAN

Miles:	6,000	12,000	18,000	24,000	30,000	36,000	42,000	48,000	54,000	60,000	66,000	72,000	78,000	84,000	90,000	96,000	102,000	108,000	114,000	120,000	126,000	132,000	138,000	144,000	150,000
Or Months:	6	12	18	24	30	36	42	48	54	60	66	72	78	84	90	96	102	108	114	120	126	132	138	144	150
Or Kilometers:	10,000	20,000	30,000	40,000	50,000	60,000	70,000	80,000	90,000	100,000	110,000	120,000	130,000	140,000	150,000	160,000	170,000	180,000	190,000	200,000	210,000	220,000	230,000	240,000	250,000
Change the engine oil and engine oil filter.	X	X	X	X	X	X	X	X	X	X	X	X	X	X	X	X	X	X	X	X	X	X	X	X	X
Rotate the tires, rotate at the first sign of irregular wear, even if it occurs before scheduled maintenance.	X	X	X	X	X	X	X	X	X	X	X	X	X	X	X	X	X	X	X	X	X	X	X	X	X
If using your vehicle for any of the following: dusty or off-road conditions. Inspect the engine air cleaner filters; replace if necessary.		X		X		X		X		X		X		X		X		X		X		X		X	
Inspect the brake linings; replace if necessary.		X		X		X		X		X		X		X		X		X		X		X		X	
Inspect the CV/Universal joints.	X	X	X	X	X	X	X	X	X	X	X	X	X	X	X	X	X	X	X	X	X	X	X	X	X

Miles:	6,000	12,000	18,000	24,000	30,000	36,000	42,000	48,000	54,000	60,000	66,000	72,000	78,000	84,000	90,000	96,000	102,000	108,000	114,000	120,000	126,000	132,000	138,000	144,000	150,000
Or Months:	6	12	18	24	30	36	42	48	54	60	66	72	78	84	90	96	102	108	114	120	126	132	138	144	150
Or Kilometers:	10,000	20,000	30,000	40,000	50,000	60,000	70,000	80,000	90,000	100,000	110,000	120,000	130,000	140,000	150,000	160,000	170,000	180,000	190,000	200,000	210,000	220,000	230,000	240,000	250,000
Inspect the exhaust system.		X		X		X		X		X		X		X		X		X		X		X		X	
Adjust the parking brake on vehicles equipped with four wheel disc brakes.					X					X					X					X					X
Drain the transfer case and refill.					X					X					X					X					X
Inspect the accessory drive belts replace if necessary.										X										X					
Inspect the front and rear axle fluid. Change if using your vehicle for any of the following: police, taxi, fleet, sustained high speed driving, off-road or frequent trailer towing.				X				X								X				X					X

Miles:	6,000	12,000	18,000	24,000	30,000	36,000	42,000	48,000	54,000	60,000	66,000	72,000	78,000	84,000	90,000	96,000	102,000	108,000	114,000	120,000	126,000	132,000	138,000	144,000	150,000	
Or Months:	6	12	18	24	30	36	42	48	54	60	66	72	78	84	90	96	102	108	114	120	126	132	138	144	150	
Or Kilometers:	10,000	20,000	30,000	40,000	50,000	60,000	70,000	80,000	90,000	100,000	110,000	120,000	130,000	140,000	150,000	160,000	170,000	180,000	190,000	200,000	210,000	220,000	230,000	240,000	250,000	
Inspect front suspension, tie rod ends, and boot seals, for cracks or leaks and all parts for damage, wear, improper looseness or end play; replace if necessary.		X		X		X		X		X		X		X		X		X		X		X		X		
Replace the engine air cleaner filters.					X					X					X					X					X	
Replace the cabin air filter.	To be replaced every 12,000 miles (19,000 km).																									
Inspect and replace the PCV Valve if necessary.															X											

Miles:	6,000	12,000	18,000	24,000	30,000	36,000	42,000	48,000	54,000	60,000	66,000	72,000	78,000	84,000	90,000	96,000	102,000	108,000	114,000	120,000	126,000	132,000	138,000	144,000	150,000	
Or Months:	6	12	18	24	30	36	42	48	54	60	66	72	78	84	90	96	102	108	114	120	126	132	138	144	150	
Or Kilometers:	10,000	20,000	30,000	40,000	50,000	60,000	70,000	80,000	90,000	100,000	110,000	120,000	130,000	140,000	150,000	160,000	170,000	180,000	190,000	200,000	210,000	220,000	230,000	240,000	250,000	
Replace the spark plugs - 6.2L Supercharged Engine. ¹										X										X						
Flush and replace the engine coolant at 120 months if not done at 150,000 miles (240,000 km).																				X						X

1. The spark plug change interval is mileage based only, monthly intervals do not apply.

WARNING!

- You can be badly injured working on or around a motor vehicle. Do only service work for which you have the knowledge and the right equipment. If you have any doubt about your ability to perform a service job, take your vehicle to a competent mechanic.
- Failure to properly inspect and maintain your vehicle could result in a component malfunction and affect vehicle handling and performance. This could cause an accident.

ENGINE COMPARTMENT

6.2L SUPERCHARGED ENGINE (BEAUTY COVER REMOVED)

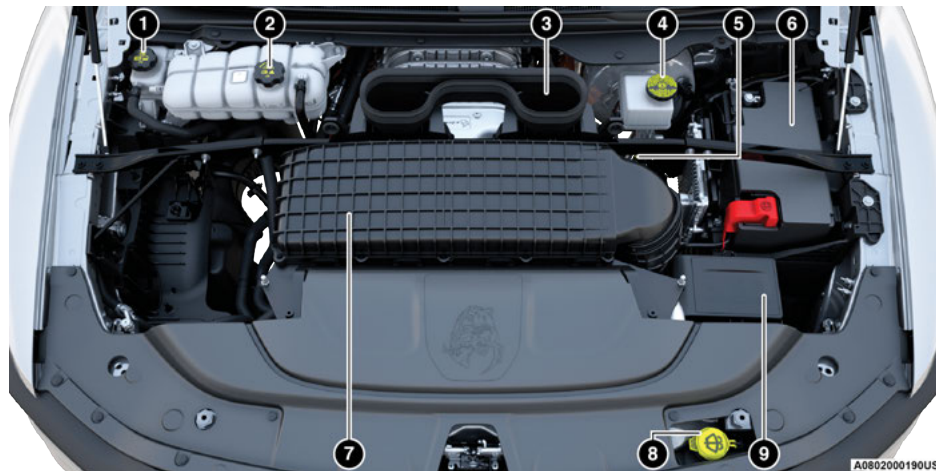

- 1 – Intercooler Coolant Reservoir Cap
- 2 – Engine Coolant Reservoir Pressure Cap
- 3 – Engine Oil Fill (behind air intake)¹
- 4 – Brake Fluid Reservoir Cap
- 5 – Engine Oil Dipstick¹

- 6 – Battery
- 7 – Engine Air Cleaner Filter
- 8 – Washer Fluid Reservoir Cap
- 9 – Power Distribution Center (Fuses)

1. See following image for further description of location.

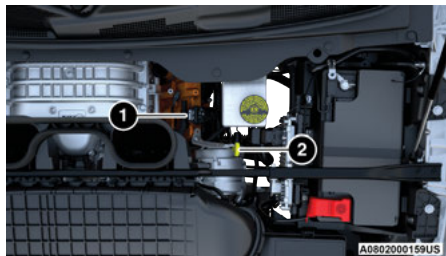

Engine Oil Fill And Dipstick Location

- 1 – Engine Oil Fill
2 – Engine Oil Dipstick

VEHICLE MAINTENANCE

An authorized dealer has the qualified service personnel, special tools, and equipment to perform all service operations in an expert manner. Service Manuals are available which include detailed service information for your vehicle. Refer to these Service Manuals before attempting any procedure yourself.

NOTE:

Intentional tampering with emissions control systems may void your warranty and could result in civil penalties being assessed against you.

WARNING!

You can be badly injured working on or around a motor vehicle. Only do service work for which you have the knowledge and the proper equipment. If you have any doubt about your ability to perform a service job, take your vehicle to a competent mechanic.

ENGINE OIL — GAS ENGINE

Engine Oil Selection 6.2L Supercharged Engine

For proper engine oil selection → page 96.

NOTE:

HEMI engines (6.2L) at times can tick right after startup and then quiet down after approximately 30 seconds. This is normal and will not harm the engine. This characteristic can be caused by short drive cycles. For example, if the vehicle is started then shut off after driving a short distance. Upon restarting, you may experience a ticking sound.

Other causes could be if the vehicle is unused for an extended period of time, incorrect oil, extended oil changes or extended idling. If the engine continues to tick or if the Malfunction Indicator Light (MIL) comes on, see the nearest authorized dealer.

CAUTION!

Do not use chemical flushes in your engine oil as the chemicals can damage your engine. Such damage is not covered by the New Vehicle Limited Warranty.

ENGINE OIL FILTER

The engine oil filter should be replaced with a new filter at every engine oil change.

Engine Oil Filter Selection

A full-flow type disposable oil filter should be used for replacement. The quality of replacement filters varies considerably. We recommend using a Mopar® Engine Oil Filter. If a Mopar® Engine Oil Filter is unavailable only use filters that meet or exceed SAE/USCAR-36 Filter Performance Requirements.

Dune Guard Removal

Removal of the dune guard under the front of the vehicle is required to remove the oil filter and drain the oil cooler.

To remove the dune guard:

1. Loosen the front two bolts, but do not remove.

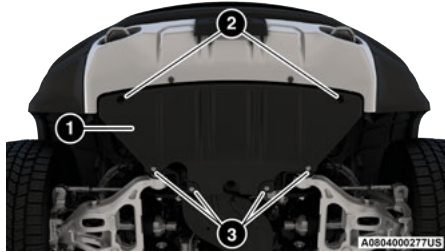

Front Underbody

- 1 – Dune Guard
- 2 – Front Bolts
- 3 – Rear Bolts

2. Remove the rear four bolts completely.
3. Slide the dune guard towards the rear of the vehicle.

NOTE:

The dune guard is heavy. Make sure to remove with the help of a partner.

Once the dune guard is removed there is access to the oil cooler drain which is behind the fascia/bumper.

NOTE:

Engine oil is drained from two locations; the engine oil pan drain bolt and the engine oil cooler drain bolt.

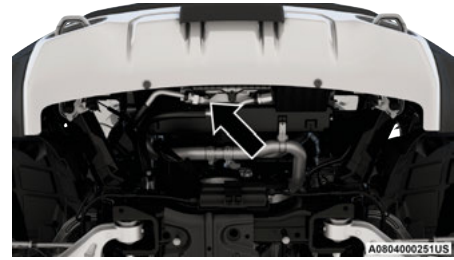

Engine Oil Cooler Drain

To reinstall the dune guard:

1. Slide the dune guard back over the two loosened fasteners at the front.
2. Hand start the rear four fasteners.
3. Once all have been started, tighten the rear four first, then the front two.

ENGINE AIR CLEANER FILTER

For the proper maintenance intervals → page 81.

NOTE:

Be sure to follow the severe duty conditions maintenance interval if applicable.

WARNING!

The air induction system (air cleaner, hoses, etc.) can provide a measure of protection in the case of engine backfire. Do not remove the air induction system (air cleaner, hoses, etc.) unless such removal is necessary for repair or maintenance. Make sure that no one is near the engine compartment before starting the vehicle with the air induction system (air cleaner, hoses, etc.) removed. Failure to do so can result in serious personal injury.

Engine Air Cleaner Filter Selection

The quality of replacement filters varies considerably. Only high quality Mopar® certified filters should be used.

Beauty Cover Removal/Installation

The engine beauty cover will need to be removed in order to service the engine air cleaner filter or to gain better access to the engine compartment.

CAUTION!

No step! Maximum force on beauty cover and engine air cleaner filter is 50 lb or less.

Beauty Cover Removal

1. Lift up on the front two corners of the beauty cover to unseat rubber ball socket fasteners.



Beauty Cover

2. Pull the cover forward to release rear guides from rubber grommets to remove from the vehicle.

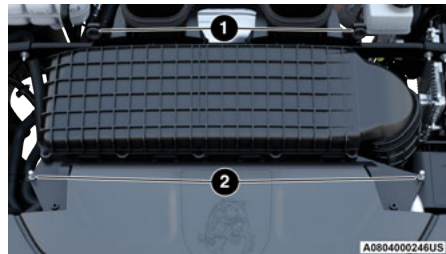

Beauty Cover Attachment Points

- 1 – Rear Grommets
- 2 – Front Ball Socket Fasteners

Beauty Cover Installation

1. Install the rear guide posts into the rubber grommets.
2. Push down on the front to seat the two rubber ball sockets in the front of the cover.

Engine Air Cleaner Filter Inspection And Replacement

NOTE:

- The beauty cover will need to be removed to access the engine air cleaner filter.
- Clean the top of the air cleaner - previously covered by beauty cover. Removing loose debris is important before lifting the engine air cleaner filter cover to prevent contamination of the clean side of the air intake system.

Engine Air Cleaner Filter Removal

1. With a suitable tool, fully loosen (ten) fasteners on the engine air cleaner filter lid and the air hose clamp.

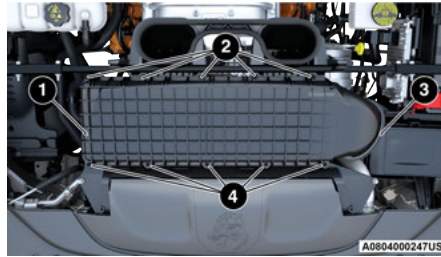

Air Cleaner Filter

- 1 – Engine Air Cleaner Filter Cover
- 2 – Rear Fasteners
- 3 – Air Hose Clamp
- 4 – Front Fasteners

2. Lift the engine air cleaner filter cover to access the filter.
3. Remove the engine air cleaner filter elements from the housing assembly.

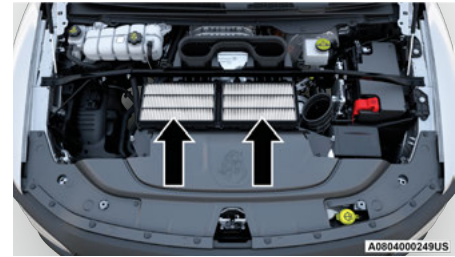

Air Cleaner Filter Elements

Engine Air Cleaner Filter Installation

NOTE:

Inspect and clean the housing if dirt or debris is present before replacing the engine air cleaner filter element.

1. Install the engine air cleaner filter elements into the housing assembly, follow "THIS SIDE UP" note on filter.
2. Install the engine air cleaner filter cover onto the housing assembly.

- Tighten the fasteners (ten) on the engine air cleaner filter assembly and the air hose clamp.

CAUTION!

Do not overtighten the engine air cleaner filter cover lid screws or damage may result.

- Reinstall the beauty cover.

COOLING SYSTEM**WARNING!**

- You or others can be badly burned by hot engine coolant (antifreeze) or steam from your radiator. If you see or hear steam coming from under the hood, do not open the hood until the radiator has had time to cool. Never open a cooling system pressure cap when the radiator or coolant bottle is hot.

(Continued)

WARNING!

- Keep hands, tools, clothing, and jewelry away from the radiator cooling fan when the hood is raised. The fan starts automatically and may start at any time, whether the engine is running or not.
- When working near the radiator cooling fan, disconnect the fan motor lead or turn the ignition to the OFF mode. The fan is temperature controlled and can start at any time the ignition is in the ON mode.

Cooling System – Drain, Flush And Refill**NOTE:**

The intercooler must be vacuum flushed and filled. If any coolant is needed to be added to the system please contact a local authorized dealer.

FUSES**General Information****WARNING!**

- When replacing a blown fuse, always use an appropriate replacement fuse with the same amp rating as the original fuse. Never replace a fuse with another fuse of higher amp rating. Never replace a blown fuse with metal wires or any other material. Do not place a fuse inside a circuit breaker cavity or vice versa. Failure to use proper fuses may result in serious personal injury, fire and/or property damage.
- Before replacing a fuse, make sure that the ignition is off and that all the other services are switched off and/or disengaged.
- If the replaced fuse blows again, contact an authorized dealer.
- If a general protection fuse for safety systems (air bag system, braking system), power unit systems (engine system, transmission system) or steering system blows, contact an authorized dealer.

CAUTION!

If it is necessary to wash the engine compartment, take care not to directly hit the fuse box, and the windshield wiper motors with water.

The fuses protect electrical systems against excessive current.

When a device does not work, you must check the fuse element inside the blade fuse for a break/melt.

Also, please be aware that when using power outlets for extended periods of time with the engine off may result in vehicle battery discharge.

Auxiliary Switches — If Equipped

Four or six auxiliary switches may be located in the lower switch bank of the instrument panel, and can be used to power various electrical devices.

The functionality of the auxiliary switches can be changed via the Uconnect Settings. All switches can be configured for setting the switch type operation to latching or momentary, power source of either battery or ignition, and ability to hold last state across key cycles.



Auxiliary Switch Location

NOTE:

Holding last state conditions are met when switch type is set to “latching” and power source is set to “ignition” within Uconnect Settings.

The auxiliary switches manage the relays that power four or six blunt cut wires. These wires are located under the hood to the right, near the battery.

In addition to the four or six auxiliary switch wires, a fused battery wire and ignition wire are also found in this location.

A kit of splices and heat shrink tubing are provided with the auxiliary switches to aid in the connection/installation of your electrical devices.

Fuse And Wire Color Chart

NOTE:

Fuses for the auxiliary switches can be found in the auxiliary Power Distribution Center (PDC), located in the engine compartment toward the front of the vehicle, in front of the main PDC. Remove upper shield to access. If equipped, additional auxiliary switch fuses will be located in the main PDC.

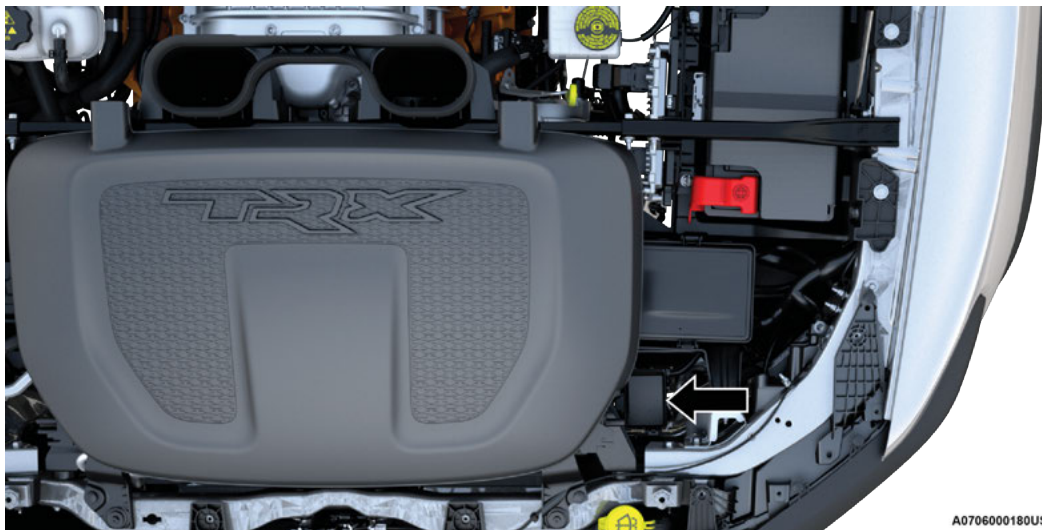

Auxiliary PDC Location

Circuit Function	Fuse	Wire Color	Location
* If Equipped			
Aux Switch 1	F001A – 50 Amp	Pink/Dark Blue	Auxiliary PDC
Aux Switch 2	F002A – 20 Amp	Pink/Dark Green	Auxiliary PDC
Aux Switch 3	F003A – 20 Amp	Pink/Violet	Auxiliary PDC
Aux Switch 4	F004A – 50 Amp	Pink/Beige	Auxiliary PDC
Aux Switch 5*	F42 – 20 Amp	Pink/Brown	Main PDC
Aux Switch 6*	F50 – 20 Amp	Pink/Yellow	Main PDC

STORING THE VEHICLE

If you are storing your vehicle for more than three weeks, we recommend that you take the following steps to minimize the drain on your vehicle's battery:

- Disconnect the negative cable from battery.
- Any time you store your vehicle or keep it out of service (i.e., vacation) for two weeks or more, run the air conditioning system at idle for about five minutes in the fresh air and high blower setting. This will ensure adequate system lubrication to minimize the possibility of compressor damage when the system is started again.

BATTERY STORAGE MODE

With the ignition in the ON position, engine not running, navigate to the battery gauge page on the instrument cluster display, then press and hold the OK button. The vehicle will be put into battery storage mode, which will greatly increase the amount of time the vehicle can sit and restart without needing to disconnect the battery. Going into battery storage mode will increase the amount of time between starts to about 60 days.

NOTE:

The key fob buttons will not work while the vehicle is in battery storage mode, pulling the door handle will wake the vehicle and allow it to recognize the key fob to unlock the door.

INTERIORS

SUEDE STEERING WHEEL CLEANING

It is sufficient to dust the steering wheel using a soft bristle brush, a dry cloth, or a vacuum cleaner with care. After having dusted, run a white cotton terry cloth that has been dampened and thoroughly wrung out over the steering wheel. Avoid the use of printed absorbent cloths/papers, as they can release ink into the material. Take extra care not to wet the steering wheel excessively; rinse the cloth or sponge and repeat as necessary. Leave to dry (overnight). Once dried, in order to restore the material, brush it delicately with a soft bristle brush.

TECHNICAL SPECIFICATIONS

FUEL REQUIREMENTS

While operating on gasoline with the required octane number, hearing a light knocking sound from the engine is not a cause for concern. However, if the engine is heard making a heavy knocking sound, see a dealer immediately. Use of gasoline with a lower than recommended octane number can cause engine failure and may void or not be covered by the New Vehicle Limited Warranty.

Poor quality gasoline can cause problems such as hard starting, stalling, and hesitations. If you experience these symptoms, try another brand of gasoline before considering service for the vehicle.

6.2L SUPERCHARGED ENGINE

Do not use E-85 flex fuel or ethanol blends greater than 15% in this engine. The use of octane boosting additives is NOT permitted for use in the 6.2L Supercharged engine.



This engine is designed to meet all emissions regulations, provide optimal fuel economy and performance when using high-quality unleaded premium gasoline having a posted octane number of 91 as specified by the (R+M)/2 method. The use of 91 or higher octane premium gasoline is required in these engines.

FLUID CAPACITIES

	US	Metric
Fuel (Approximate)		
All	33 gal	124.9 L
Engine Oil With Filter (After Draining Oil Cooler)		
6.2L Engine	7.5 qt	7.1 L
Cooling System		
6.2L Engine	18.7 qt	17.7 L
6.2L Engine Intercooler	3.75 qt	3.55 L

ENGINE FLUIDS AND LUBRICANTS

Component	Fluid, Lubricant, or Genuine Part
Engine/Intercooler Coolant	We recommend using Mopar® Antifreeze/Coolant 10 Year/150,000 Mile (240,000 km) Formula OAT (Organic Additive Technology) that meets the requirements of the manufacturer Material Standard MS.90032.
Engine Oil – 6.2L Engine	We recommend using Mopar® API Certified SAE 0W-40 Full Synthetic Engine Oil which meets the requirements of the manufacturer Material Standard MS-A0921. Equivalent full synthetic SAE 0W-40 engine oil can be used but must have the API Donut trademark.
Fuel Selection – 6.2L Engine	Premium Unleaded 91 Octane Only or Higher (R+M)/2 Method, 0-15% Ethanol (Do Not Use E-85).

CAUTION!

- Mixing of engine coolant (antifreeze) other than specified Organic Additive Technology (OAT) engine coolant (antifreeze), may result in engine damage and may decrease corrosion protection. Organic Additive Technology (OAT) engine coolant is different and should not be mixed with Hybrid Organic Additive Technology (HOAT) engine coolant (antifreeze) or any “globally compatible” coolant (antifreeze). If a non-OAT engine coolant (antifreeze) is introduced into the cooling system in an emergency, the cooling system will need to be drained, flushed, and refilled with fresh OAT coolant (conforming to MS.90032), by an authorized dealer as soon as possible.
- Do not use water alone or alcohol-based engine coolant (antifreeze) products. Do not use additional rust inhibitors or antirust products, as they may not be compatible with the radiator engine coolant and may plug the radiator.
- This vehicle has not been designed for use with propylene glycol-based engine coolant (antifreeze). Use of propylene glycol-based engine coolant (antifreeze) is not recommended.

GENERAL INFORMATION

The following regulatory statement applies to all Radio Frequency (RF) devices equipped in this vehicle:

This device complies with Part 15 of the FCC Rules and with Innovation, Science and Economic Development Canada license-exempt RSS standard(s). Operation is subject to the following two conditions:

1. This device may not cause harmful interference, and
2. This device must accept any interference received, including interference that may cause undesired operation.

Le présent appareil est conforme aux CNR d'Innovation, Science and Economic Development applicables aux appareils radio exempts de licence. L'exploitation est autorisée aux deux conditions suivantes:

1. l'appareil ne doit pas produire de brouillage, et
2. l'utilisateur de l'appareil doit accepter tout brouillage radioélectrique subi, même si le brouillage est susceptible d'en compromettre le fonctionnement.

La operación de este equipo está sujeta a las siguientes dos condiciones:

1. es posible que este equipo o dispositivo no cause interferencia perjudicial y
2. este equipo o dispositivo debe aceptar cualquier interferencia, incluyendo la que pueda causar su operación no deseada.

NOTE:

Changes or modifications not expressly approved by the party responsible for compliance could void the user's authority to operate the equipment.

INDEX

- A**
- Air Cleaner, Engine
 - (Engine Air Cleaner Filter) 88
 - Air Filter 88
 - Alterations/Modifications
 - Vehicle 5
 - Antifreeze (Engine Coolant) 95
 - Automatic Transmission 21
 - Gear Ranges 21
 - Automatic Transmission Limp Home Mode 23
 - Auxiliary Switches 91
- B**
- Brake/Transmission Interlock 20
- C**
- Camper 5
 - Capacities, Fuel 95
 - Caps, Filler
 - Oil (Engine) 85
 - Checking Your Vehicle For Safety 68
 - Checks, Safety 68
 - Cooling System 90
 - Cooling Capacity 95
 - Drain, Flush, And Refill 90
 - Selection Of Coolant (Antifreeze) 95, 96
- D**
- Dealer Service 86
 - Driving 33
- E**
- Electronic Stability Control (ESC).....66
 - Electronically Shifted Transfer Case24
 - Engine.....85
 - Air Cleaner88
 - Break-In Recommendations 19
 - Compartment85
 - Compartment Identification.....85
 - Coolant (Antifreeze)96
 - Fuel Requirements94, 95
 - Oil86, 95, 96
 - Oil Filler Cap85
 - Oil Filter86
 - Oil Selection.....86, 95
 - Engine Oil Cooler.....87

F

Filters	
Air Cleaner.....	88
Engine Oil.....	86, 96
Flat Tire Stowage.....	76
Fluid Capacities.....	95
Fluid Leaks.....	68
Four Wheel Drive.....	24
Fuel.....	94
Gasoline.....	94
Octane Rating.....	94, 96
Requirements.....	94, 95
Tank Capacity.....	95
Fuses.....	90

G

Gear Ranges.....	21
------------------	----

H

Head Up Display.....	16
----------------------	----

I

Instrument Cluster.....	9
Descriptions.....	10
Diagnostics.....	14
Display.....	10
Display Controls.....	11
Drive Modes.....	17
HUD.....	15
Menu Items.....	11
Off road.....	14
Speed Warning.....	15
Vehicle Info.....	12
Instrument Cluster Display	
Settings.....	15
Interior Appearance Care.....	93
Inverter Outlet (115V).....	8

J

Jack Location.....	69
--------------------	----

L

Lead Free Gasoline.....	94
Leaks, Fluid.....	68
Lights	
Baja Mode.....	18
Custom Mode.....	18
Mud/Sand Mode.....	18
Rock Mode.....	18
Snow Mode.....	18
Sport Mode.....	18
Tow Mode.....	18
Valet Mode.....	18
Warning Instrument Cluster Descriptions.....	18

M

Maintenance Schedule.....	79
Modifications/Alterations	
Vehicle.....	5

N

New Vehicle Break-In Period..... 19

O

Octane Rating, Gasoline (Fuel) 94

Oil Filter, Change 86

Oil Filter, Selection..... 86

Oil, Engine 86, 96

Capacity 95

Filter..... 86, 96

Recommendation 86, 95

Viscosity 95

P

Paddle Shifters 23

Performance Features 13

Power

Outlet (Auxiliary Electrical Outlet) 8

S

Safety Tips 68

Schedule, Maintenance 79

Selec - Speed Control 27

Selection Of Coolant (Antifreeze) 96

Shifting 19

Automatic Transmission 21

Storage 7

Storage, Vehicle..... 93

Storing Your Vehicle..... 93

T

Transfer Case

Electronically Shifted 24

Transmission..... 21

Automatic 21

Shifting 19

U

Unleaded Gasoline..... 94

V

Vehicle Maintenance 86

Vehicle Modifications/Alterations 5

Vehicle Storage 93





SCAN TO ACCESS YOUR
VEHICLE'S VIDEO PLAYLIST

©2022 FCA US LLC. All Rights Reserved. Tous droits réservés. Ram is a registered trademark of FCA US LLC.
Ram est une marque déposée de FCA US LLC. App Store is a registered trademark of Apple Inc. Google Play Store is a registered trademark of Google.



P68611075AA
FIRST EDITION